

WorkHorse Series 3

Ferroresonant Battery Chargers

FEATURING dv/dt - di/dt CONTROLS

Installation and Operating Instructions



www.appliedenergysol.com
One Technology Place
Caledonia, NY 14423
(585) 538 – 4421

The Power of Excellence

FM1248
REV G

TABLE OF CONTENTS

SECTION 1	SAFETY INSTRUCTIONS	3
SECTION 2	RECEIPT AND INSPECTION OF THE CHARGER	4
SECTION 3	INTRODUCTION	4
SECTION 4	CONTROL FEATURES	4
SECTION 5	INSTALLATION	7
SECTION 6	OPERATING PROCEDURE	8
SECTION 7	CHARGER CABINETS	10
SECTION 8	OPTIONAL FEATURES	11
SECTION 9	MAINTENANCE	12
SECTION 10	TROUBLESHOOTING GUIDE	16
SECTION 11	SCHEMATICS	18

SECTION 1 SAFETY INSTRUCTIONS

IMPORTANT SAFETY INSTRUCTIONS

1. SAVE THESE INSTRUCTIONS. THIS MANUAL CONTAINS IMPORTANT SAFETY AND OPERATING INSTRUCTIONS.
2. WORKING IN THE VICINITY OF A LEAD-ACID BATTERY IS DANGEROUS. BATTERIES GENERATE EXPLOSIVE GASSES DURING NORMAL BATTERY OPERATION. FOR THIS REASON IT IS OF THE UTMOST IMPORTANCE THAT EACH TIME BEFORE USING YOUR CHARGER, YOU READ AND FOLLOW THE INSTRUCTIONS PROVIDED EXACTLY.
3. TO REDUCE RISK OF BATTERY EXPLOSION, FOLLOW THESE INSTRUCTIONS AND THOSE ON THE BATTERY.
4. NEVER SMOKE OR ALLOW AN OPEN SPARK OR FLAME IN THE VICINITY OF THE BATTERY OR ENGINE.
5. USE CHARGER FOR CHARGING A LEAD-ACID BATTERY ONLY. IT IS NOT INTENDED TO SUPPLY POWER TO AN EXTRA LOW-VOLTAGE ELECTRICAL SYSTEM OR TO CHARGE DRY-CELL BATTERIES. CHARGING DRY-CELL BATTERIES MAY CAUSE THEM TO BURST AND CAUSE INJURY TO PERSONS AND DAMAGE TO PROPERTY.
6. NEVER CHARGE A FROZEN BATTERY.
7. DO NOT OPERATE IN A CLOSED-IN AREA OR RESTRICT VENTILATION IN ANY WAY.
8. DANGER: RISK OF ELECTRICAL SHOCK. DO NOT TOUCH UNINSULATED PORTION OF OUTPUT CONNECTOR OR UNINSULATED BATTERY TERMINAL.
9. CAUTION: DISCONNECT SUPPLY BEFORE CHANGING FUSE.

INSTRUCTIONS IMPORTANTES CONCERNANT LA SECURITE

1. CONSERVER CES INSTRUCTIONS. CE MANUEL CONTIENT DES INSTRUCTIONS IMPORTANTES CONCERNANT LA SECURITE ET LE FONCTIONNEMENT.
2. IL EST DANGEREUX DE TRAVAILLER A PROXIMITE D'UNE BATTERIE AU PLOMB. LES BATTERIES PRODUISENT DES GAS EXPLOSIFS EN SERVICE NORMAL. AUSSI EST-IL IMPORTANT DE TOUJOURS RELIRE LES INSTRUCTIONS AVANT D'UTILISER LE CHARGEUR ET DE LES SUIVRE A LA LETTRE.
3. POUR REDUIRE LE RISQUE D'EXPLOSION, LIRE CES INSTRUCTIONS ET CELLES QUI FIGURENT SUR LA BATTERIE.
4. NE JAMAIS FUMER PRES DE LA BATTERIE OU DU MOTEUR ET EVITER TOUTE ETINCELLE OU FLAMME NUE A PROXIMITE DE CES DERNIERS.
5. UTILISER LE CHARGEUR POUR CHARGER UNE BATTERIE AU PLOMB UNIQUEMENT. CE CHARGEUR N'EST PAS CONCU POUR ALIMENTER UN RESEAU ELECTRIQUE TRES BASSE TENSION NI POUR CHARGER DES PILES SECHES. LE FAIT D'UTILISER LE CHARGEUR POUR CHARGER DES PILES SECHES POURRAIT ENTRAINER L'ECLATEMENT DES PILES ET CAUSER DES BLESSURES OU DES COMMAGES.
6. NE JAMAIS CHARGER UNE BATTERIE GELEE.
7. NE PAS FAIRE FONCTIONNER LE CHARGEUR DANS UN ESPACE CLOS ET/OU NE PAS GENER LA VENTILATION.
8. DANGER: RISQUE DE CHOCS ELECTRIQUES. NE PAS TOUCHER LES PARTIES NON ISOLEES DU CONNECTEUR DE SORTIE OU LES BORNES NON ISOLEES DE L'ACCUMULATEUR.
9. ATTENTION: COUPER L'ALIMENTATION AVANT DE REMPLACER LES FUSIBLES.

SECTION 2 RECEIPT AND INSPECTION OF THE CHARGER

Upon receipt of the charger the information on the shipping carton should be checked against your order. Any discrepancies should be reported to the nearest authorized representative. Whenever possible, move the charger to the installation site before uncrating. All chargers can be handled with a lift truck by inserting the forks under the bottom of the charger. Remove the carton and inspect the charger for damage. If there is any damage, save the carton for inspection and notify the carrier immediately. Check the nameplate & labels against your order & specifications. Any discrepancies should be reported immediately to the nearest AES authorized representative.

SECTION 3 INTRODUCTION

SERIES 3 Industrial Battery Chargers are full wave silicon rectified ferroresonant chargers. Charging current is regulated by the ferroresonant transformer(s). The ferroresonant transformers allow the battery to determine its own charge rate with respect to its state of discharge. The control is a custom dv/dt-di/dt termination PCB assembly for flooded lead-acid battery chargers. A solid state, pre-programmed microcomputer provides total control of charge termination, preventing both undercharging and overcharging. The microcomputer incorporates built-in fault detection to ensure correct battery connection and smooth operation. The charge is terminated automatically when the control determines that the battery is fully charged.

SECTION 4 CONTROL FEATURES

- Automatic five-second delayed start upon connection of a proper sized, good battery.
- Battery voltage sensing determines if there is a proper sized battery connected to the charger. This prevents charging if there is a bad battery connected, no battery connected, bad battery-to-charger connection or battery voltage and charger mismatch.
- Battery voltage and current are continuously monitored.
- Automatic dv/dt-di/dt charge termination.
- Negative battery slope termination to prevent overcharge/thermal runaway.
- Automatic 12-hour "Refresh" adds a top off charge to a fully charged battery. The charger will start a "refresh" charge 12 hours after a normal charge complete has been reached, assuming that the battery was not disconnected during that time. Automatic refresh may be disabled by removing R35 on the control board assembly.
- Backup Timers prevent extended charging of a damaged battery. The first timer starts at the beginning of the charge cycle and runs for 9 hours. At 9 hours, if the battery has not reached the 80% point, the charger will shutdown. The second timer starts at the 80% point and runs for 6 hours. If the charger does not terminate by then it will shutdown.

- Automatic Shutdown Lockout will not allow a charge to start after a manual or problem shutdown occurs. Automatic Shutdown Lockout is cleared after the "shutdown" battery is disconnected. This allows a charge to begin upon connection of a good, proper sized battery.
- Automatic shutdown occurs for any of five failure conditions:
 - Fault code “**Lo U**” – Low volts per cell – the battery voltage is less than 1.7V/Cell. The charger will not be “locked off.” The charger will automatically start charging when the battery voltage is greater than 1.7V/Cell.
 - Fault code “**Hi U**” – High volts per cell – greater than 2.8 or 2.88 V/Cell (set with 80% point).
 - Fault code “**dISC**” – Battery disconnected from charger during charge.
 - Fault code “**dur**” – Charge time exceeded – backup timer expired
 - Fault code “**Lo I**” – Low charging current – charging current less than approximately 3 amps.
- Manual STOP switch - Will stop the charger from charging. The display will indicate “OFF” until the battery is disconnected. When pressed with no battery connected, displays the delay start setting. When pressed during watering mode, will terminate watering but allow refreshes if the battery remains connected.
- One to nine hour programmable delayed start thumbwheel switch. This rotary switch can be set from 0 to 9 hours to delay the start of charge.
- Optional Automatic Equalization cycle every 5th cycle. This option can be enabled by DIPswitch #5. For a completed charge cycle to be counted, the battery must be on charge at less than 80% for 1 hour or more from start of charge.
- Equalize switch - The switch when depressed will turn on and off the three-hour additional manual equalizing charge. When the Equalize function is turned on, an “E” will be displayed in the leftmost digit of the display. The “E” will flash during the actual equalize charge cycle (manual and automatic). If auto-equalize has been selected, pressing this switch prior to connecting the battery will allow the number of charge cycles remaining before auto-equalize cycle to be displayed in the format ‘E-#’.
- LED TEST switch - All the LED’s and display segments will illuminate when this switch is pressed.
- Display mode switch:
 - Press once to display AMP-HOURS RETURNED
 - Press twice to display TOTAL CHARGE TIME
 - Press three times to display average BATTERY VOLTAGE/CELL
- LED Indicators:
 - CHARGING” - charger is charging the battery.
 - 80%” - the battery voltage is greater than 2.37 (or 2.45) V per cell.
 - CHARGE COMPLETE - the charge cycle has been terminated normally.
 - SHUTDOWN - the unit has shut down for a fault.

- DIGITAL DISPLAY Readout will display the following information:
 - Charging current
 - Fault codes
 - Delay start time
 - Equalize mode
 - Charge time
 - Cool-down time
 - Battery voltage
 - Amp-hour returned
 - Watering Cycle

- Watering Function - A watering signal is provided at controller connector pin P3-3. This low current signal is normally logic level 'lo' and goes 'hi' at the end of every Charge cycle (watering mode). When in the watering mode the signal pulses on for 15 sec. and off for 15 sec. for a total of 20 repetitions or on continuously for 5 min (Dipswitch selectable). To prevent over-watering, this signal will not occur if the charge reaches 80% in less than 5 min. from start of charging. This signal is meant to interface with an external circuit for operating a watering valve. During watering the display shows 'H2O'. If equalize charge is selected, watering occurs immediately after the equalize cycle.

- DIP SWITCH Settings:

NOTE: Normal factory settings are all DIPswitches set in the "ON" position except for units designed for 50 Hz applications.

Switch Position	ON	OFF
1	Single di/dt compensation	Double di/dt compensation
2	Normal dv/dt termination	Triple dv/dt termination
3	60 Hz operation	50 Hz operation
4	Display cool-down time	Do not display cool-down time
5	Auto-Equalize Disabled	Auto-equalize enabled
6	Normal current display	Double current display
7	Water signal is pulsed	Water signal is continuous
8	80% point – 2.37 V/Cell	80% point – 2.45 V/Cell

SECTION 5 INSTALLATION

5.1 PHYSICAL LOCATION:

Charging areas should be clean and dry. The temperature of the charging room should be between 32°F (0°C) and 77°F (25°C), with occasional and brief periods of ambient temperature as high as 104°F (40°C). Combustible materials, open flames and smoking should not be permitted in or near the charging room.

WARNING

A BATTERY ON CHARGE WILL EMIT EXPLOSIVE GAS.
VENTILATE THE CHARGING ROOM TO PREVENT GAS ACCUMULATION.

5.2 MOUNTING:

The SERIES 3 charger cabinets must be mounted on a surface constructed from non-combustible material, such as stone, brick, concrete or metal. Mounting holes are provided in the frame for securing the charger.

5.3 INPUT POWER CONNECTION:

All chargers are shipped from the factory connected for the input voltage specified on your purchase order. A "STOP" label, located inside the door, indicates the factory set input voltage.

WARNING

VERIFY THAT THE AC ELECTRICAL SERVICE IS DISCONNECTED AT THE BREAKER
BEFORE ATTEMPTING TO CONNECT AC POWER TO THE CHARGER.

The AC input terminals are identified by a red-on-white AC INPUT Label located on the base near the fuse block. The AC input cable is to be connected to the proper AC INPUT terminals within the charger cabinet.

The fuse block's input terminals are rated for 14 AWG to 2 AWG wire. The recommended torque is listed on the fuse block itself.

A green grounding wire is to be connected from the grounding terminal within the charger cabinet to the service system ground. The grounding terminal is identified by a green-on-white ground terminal label on the charger base. If a system ground is not available, the charger frame must be connected to a driven ground rod in accordance with National and Local Electrical Codes. Proper application and tight terminal connections are important in avoiding future problems. The ground terminal is rated for 14 awg to 6 awg wire. The recommended torque setting is shown in Table 5.1

Table 5.1

Wire Gauge	Recommended Torque Setting
PANDUIT LAMA6-14Q	
6 – 10 AWG	40 in lbs
12 – 14 AWG	15 in lbs
T&B ADR6	
6 AWG	35 in lbs
8 – 14 AWG	20 in lbs

The charger is normally furnished with an output charge plug or receptacle. Verify that the connectors on both the battery and the charger are correct. Verify that when connected, the positive polarity (red) of the charger is connected to the positive terminal of the battery.

If the charger is to be used at a different AC voltage than presently set for, the charger may be adjusted to operate for the different AC service. Refer to Section 9.2 CHARGER ADJUSTMENTS.

SECTION 6 OPERATING PROCEDURE

6.1 PRELIMINARY SET-UP:

Once power has been applied to the charger, a "dash" will sequence across the display on the front panel. This indicates the charger is in the "IDLE MODE" of operation, awaiting a battery connection.

6.2 IMMEDIATE/DELAY START:

The control may be programmed to delay the start of the charge from one to nine hours as well as an immediate start of the charge upon battery to charger connection. Note: all units are shipped from the factory set for immediate start (no start delay).

If a power failure occurs, no damage will occur to the battery or the charger. If a battery is still connected when power returns, the control will override any delayed start setting and initialize an immediate start of the charge. Once the charge has been terminated, the delay start will function normally thereafter.

- Remove AC power from the charger.
- Open the charger cabinet door.
- Locate the DELAY START thumbwheel switch behind the front panel at the bottom of the control board. Adjust the DELAY START thumbwheel switch until the NUMBER INDICATOR on the switch yields the number of delay hours desired.
- Close and secure the cabinet door.
- Apply AC power to the charger.
- When a good, proper sized battery is connected to the charger, the display will indicate the amount of time remaining before the charge is initiated and the control will begin a countdown to charge.

6.3 CHARGING THE BATTERY:

Compare the number of cells and amp-hour capacity of the battery to be charged with the charger rating found on the charger nameplate. The number of cells in the battery to be charged **MUST** match the nameplate data. The Amp-Hour ratings should also match for timely charging of the battery. Once the battery to be charged has been determined to match the charger, the battery may be connected to the charger. The control will measure the average V/cell of the connected battery. If the control has verified the connection of a good battery (between 1.7 and 2.8 V/cell), the display will show a countdown to charge initialization and the LED's will be flashing. When the countdown reaches zero, the control will turn on the charging transformers. If the average V/cell reading is less than 1.7V, the display shows "Lo U," the charge will not begin and the red SHUTDOWN LED will be flashing. If the average V/cell is greater than 2.8V, the display shows "HI U" and the red SHUTDOWN LED will illuminate. Again, the charge will not begin. Once the charge begins, the display will show the output charging current in amperes. The green CHARGING LED will illuminate. The yellow 80% CHARGED LED will illuminate if the average V/cell of the battery is greater than 2.37 V/Cell.

6.4 TERMINATION OF CHARGE:

There are three ways in which the charge may be terminated. These three termination methods are charge complete termination via dv/dt - di/dt slope, manual termination, and problem shutdown termination.

- Charge complete termination occurs when a battery reaches full charge. The control monitors the battery charge characteristics. The control utilizes di/dt current compensation to obtain an accurate battery voltage charging slope, dv/dt measurement. Once the control has verified that the battery charge slope has reached the pre-determined value for full charge, the charge is terminated automatically. Once the charge is completed and terminated, the green CHARGE COMPLETED LED will illuminate. The display will show the battery cool-down time.
- Manual termination, while charging, is accomplished by pressing the STOP push-button switch located on the front panel.

IMPORTANT

To remove a charging battery from the charger, it is important to press the STOP push-button switch before disconnecting the battery from the charger. Failure to do this may damage the charger.

When the charge has been terminated due to MANUAL TERMINATION, the red SHUTDOWN LED will be ON continuously (until the battery is removed). The display will show "OFF."

- Problem shutdown termination:

Each PROBLEM SHUTDOWN termination is indicated by a flashing red SHUTDOWN LED and a FAULT code, along with a display decimal indicator. After the battery is removed, the red SHUTDOWN LED will remain flashing for one hour. The display indicator will remain on until the battery is disconnected from the charger. Refer to Section 4 for a more complete explanation of the diagnostics.

- Refresh Charge:

When a battery remains connected to the charger for 12 hours after the charge has been completed, the control will restart another charge cycle. The charge rate of the battery will be monitored with dv/dt - di/dt termination occurring typically within 35 minutes. When the charger is in this REFRESH mode, the charge amps will be displayed, the CHARGING and 80% CHARGED LED's will illuminate, and the CHARGE COMPLETE LED will be blinking.

A two-day weekend will have from three to five REFRESH cycles. Refresh cycles may be disabled by removal of R35.

6.5 LED TEST:

The LED TEST switch may be pushed to illuminate all LED's and display segments, to ensure that all are functional.

6.6 THREE-HOUR EQUALIZE CYCLE:

- A 3-hour automatic equalization cycle will occur every 5th charging cycle when this feature is enabled. A completed cycle is counted only if 1 hour or more time is required to reach 80% charged from charge start. To enable, set DIP SW 5 to OFF.
- Manual equalization button when pushed will provide a timed three-hour charge extension after dv/dt - di/dt termination has been reached. It will not reset the automatic equalize counter, if auto-equalize is enabled.

SECTION 7 CHARGER CABINETS

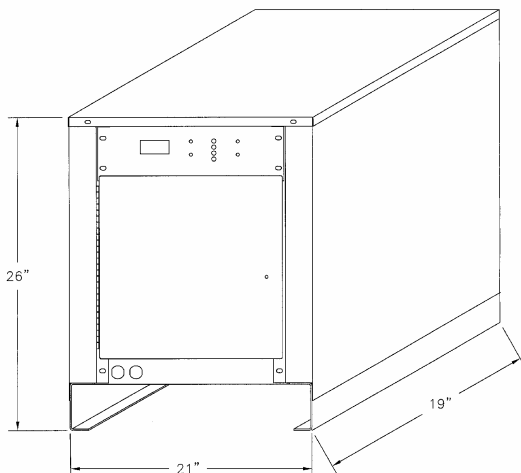

SINGLE PHASE

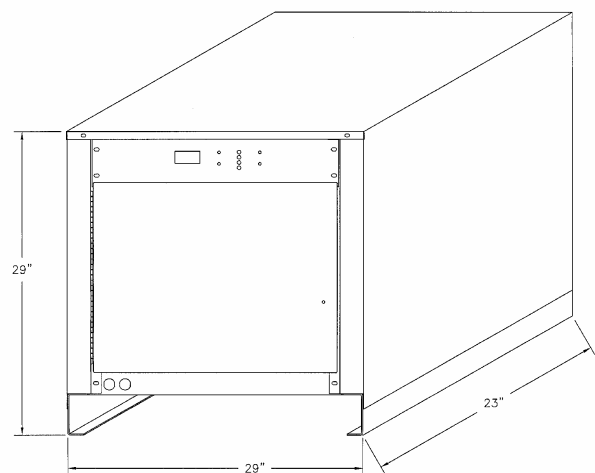

THREE PHASE

SECTION 8 OPTIONAL FEATURES

8.1 PARALLEL CHARGING OUTPUT CABLES:

Parallel charging output cables are an extra set of DC cables which permit two batteries with the same number of cells and amp-hour capacity to be charged simultaneously in parallel.

The number of cells of each battery to be charged MUST equal the number of cells indicated on the charger nameplate. The combined amp-hour capacity of the two batteries must be within the range of the charger. (Example: Two 24 volt, 12 cell, 240 amp-hour batteries connected in parallel could be charged by one 24 volt, 12 cell, 480 amp-hour charger.)

This option is available for all SERIES 3 battery chargers.

8.2 SERIES CHARGING OUTPUT CABLES:

Series charging output cables are an extra set of DC cables, which allow two batteries with the same number of cells, amp-hour capacity and depth of discharge to be charged simultaneously in series. To charge two batteries in series, the total sum of the battery cells MUST be equal to the number of cells stated on the charger nameplate. The amp-hour capacity of EACH battery must equal the amp-hour rating of the charger. (EXAMPLE: Two 12 volt, 6 cell, 480 amp-hour batteries can be connected in series and charged by one 24 volt, 12 cell, 480 amp-hour charger.

The series charging output cable option is available for all SERIES 3 battery chargers. This configuration of charge cables does NOT permit charging of only one battery.

8.3 50 Hz OPERATION:

- The SERIES 3 battery chargers may be ordered to run on a 50 Hz AC input.
- 60 Hz AC input chargers cannot be reconfigured (reconnected) to operate at 50 Hz or vice-versa.

SECTION 9 MAINTENANCE

IMPORTANT

BEFORE PERFORMING ANY MAINTENANCE ON THE CHARGER:

- If a battery is being charged, terminate the charge by pressing the STOP button.
- Disconnect the battery from the charger.
- Remove AC power from the charger.

WARNING

HIGH VOLTAGES EXIST WITHIN THE CHARGER, WHICH CAN CAUSE SEVERE INJURY OR DEATH. SERVICE SHOULD BE PERFORMED ONLY BY QUALIFIED SERVICE PERSONNEL. IMPROPER SERVICING MAY DAMAGE THE CHARGER.

9.1 MONTHLY PREVENTIVE MAINTENANCE

- If a battery is being charged, terminate the charge by pressing the STOP button.
- Disconnect the battery from the charger.
- Remove AC power from the charger.
- Using compressed air, remove any dust from the inner cabinet walls and internal components of the charger.
- Wipe the exterior of the cabinet and clear any obstructions from the ventilation louvers.
- Make sure that all bolted or screwed electrical connections are tight.
- Make sure that the insulation on all cables and wires is in good condition. Replace if necessary.

9.2 CHARGER ADJUSTMENTS:

- CHANGING THE AC INPUT LINE VOLTAGE:

SERIES 3 chargers are designed to operate at different voltage levels. The chargers can be ordered for 120/240V single phase and 208/240/480V, 240/480/575V, 60 Hz or 220/380/440V, 50 Hz, single or three phase electric services depending on the charger.

If the charger is to be operated on a different rated input voltage than the ordered value, follow the voltage changeover instructions described below.

- VOLTAGE CHANGEOVER INSTRUCTIONS:
 1. Manually terminate the charging battery by pressing the STOP button and disconnect battery from charger.
 2. Remove AC power from the charger.
 3. Locate the Terminal Block with Jumpers (one Terminal Block per phase) and the label describing the various voltage/jumper configurations. (Refer to Fig. 9.1A, B or C). The Terminal Block with Jumpers is located on the Ferroresonant Transformer.

4. Change the jumpers in accordance with the Jumper label, located within the charger cabinet, for the voltage input configuration desired.
5. Locate the AC fuses and fuse label. Change the fuses to the appropriate value as indicated by the punched or circled values on the fuse label.
6. Locate the Control transformer. Change the primary input connection in accordance with the voltage printed on the transformer. (Refer to Fig. 9.2A, B, or C.)
7. Change the voltage level on the STOP label to the new voltage level.
8. CHECKLIST:
 - Verify that the Terminal Block(s) with Jumpers are configured correctly. Make sure that all the Terminal Blocks with Jumpers have been changed properly, and connections are tight.
 - Verify the installation of properly rated fuses.
 - Verify that the Control Transformer primary taps have been changed correctly.
 - Verify that the STOP label, located inside the door, has been corrected to the new input voltage level that the charger is set for.
 - Close and secure the cabinet.
 - Reapply AC power to the charger.

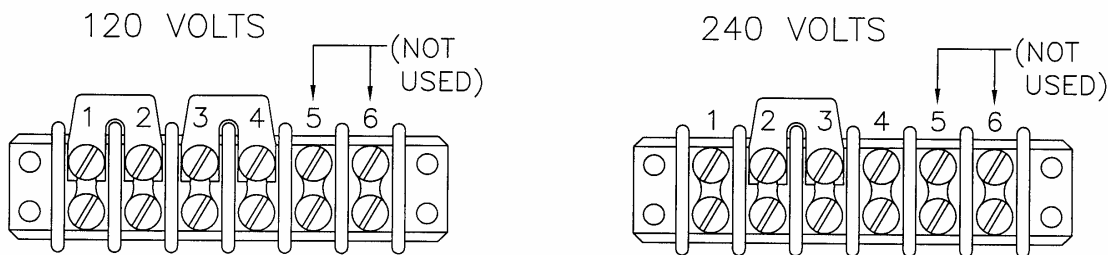

Fig. 9.1A A.C. Voltage Selector Blocks

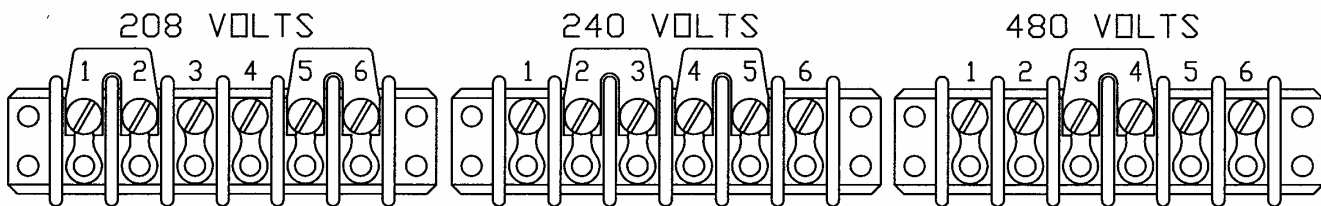

Fig. 9.1B A.C. Voltage Selector Blocks

NOTE: For 3 phase units there are 3 identical blocks, all 3 must be set to the appropriate voltage.

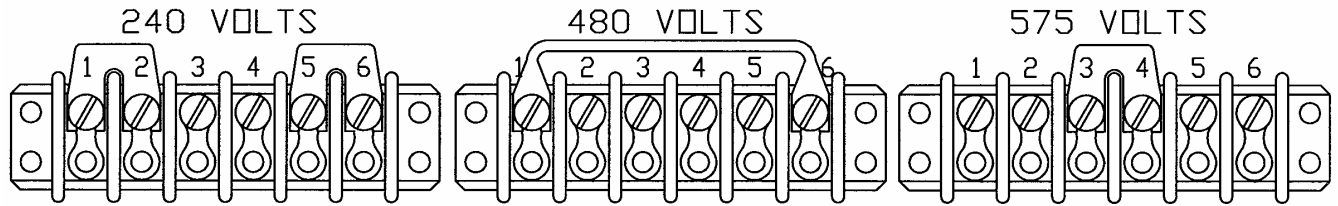

Fig. 9.1C A.C. Voltage Selector Blocks

NOTE: For 3 phase units there are 3 identical blocks, all 3 must be set to the appropriate voltage.

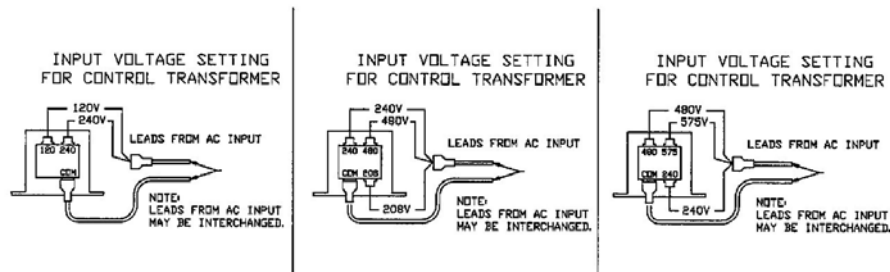

Fig. 9.2A, B, C A.C. Voltage Selection on Primary Side of Control Transformer

- CHARGING CURRENT START & FINISH RATE ADJUSTMENT:

WARNING

HIGH VOLTAGES EXIST WITHIN THE CHARGER, WHICH CAN CAUSE SEVERE INJURY OR DEATH. SERVICE SHOULD BE PERFORMED ONLY BY QUALIFIED SERVICE PERSONNEL. IMPROPER SERVICING MAY DAMAGE THE CHARGER.

Each of the SERIES 3 Ferroresonant Transformers has multiple taps for the Resonant Capacitor. These allow the charger output current to be adjusted to accommodate variations in the AC line voltage.

Figure 9.3 is a schematic representation of the Ferroresonant Transformer Resonant Winding Taps and the Resonant Capacitor. There are six Resonant Winding Taps numbered 7-12. By connecting the Resonant Capacitor to taps 7 and 12, the charger will be set for maximum output current. The Resonant Winding can then be reduced in 5% increments down to a maximum reduction of 30%. The taps to select for a given reduction are shown in Table 9.1.

Each Ferroresonant Transformer is factory set for a nominal charging current start and finish rate of 18% & 5% respectively of the chargers maximum amp-hour rating. If it is necessary to change the battery charging current start and finish rate, refer to Table 9.1 and follow this procedure:

- Manually terminate the charging battery by pressing the STOP button. Disconnect the battery from the charger.

- Remove AC power from the charger.
- Locate Resonant Winding Taps 7 through 12 on each of the Ferroresonant Transformers. Note which taps are connected to the Resonant Capacitor.
- Use Table 9.1 to determine which of the taps is to be connected for an increase or decrease in the charging current rate. Adjustments should be made in 5% increments.
- Verify the proper connection of each Ferroresonant Transformer to its respective capacitor. Each Ferroresonant Transformer should be tapped the same for proper operation.
- Close and secure the charger cabinet.
- Connect the AC input line to the AC source.

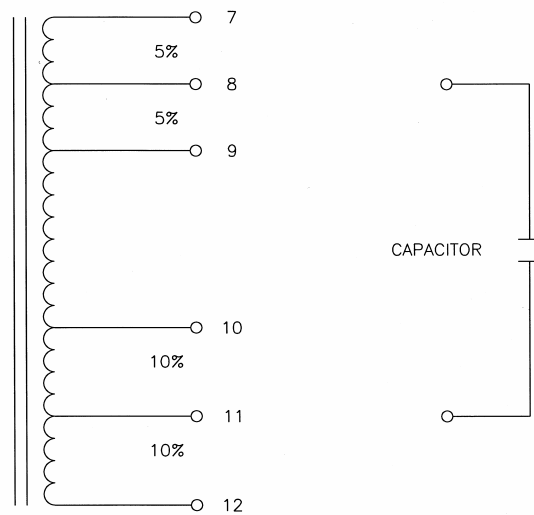

Fig. 9.3 Ferroresonant Transformer Capacitor Winding

Table 9.1

Resonant Winding Tap Connection For Start/Finish Rate Charging Current Adjustment

	Charging Current Start/Finish Rate Adjustment	Ferroresonant Transformer Tap Connection
Maximum Start/Finish Rate	115%	7 and 12
	110%	8 and 12
	105%	9 and 12 or 7 and 11
	100%	8 and 11
	95%	7 and 10 or 9 and 11
	90%	8 and 10
Minimum Start/Finish Rate	85%	9 and 10

SECTION 10 TROUBLESHOOTING GUIDE

Locate the symptom your charger is experiencing and follow the step by step troubleshooting procedure to determine the cause of the problem. Refer to circuit diagrams in Section 11.

SYMPTOM #1 - POWER IS APPLIED BUT THE DISPLAY IS NOT ON

1. AC power connections:

Make sure the AC input line, located at the AC FUSE BLOCK, is connected to the AC power outlet. Measure the voltage and verify that AC power is at the charger.

2. Control transformer:

Locate the Control Transformer. Measure the AC input voltage at the Control Transformer primary. If there is no voltage measured, repair open circuit.

Measure the Control Transformer secondary voltage across terminals 5 and 7. The AC voltage should be approximately 18 to 20 VRMS. If no voltage is measured, then the Control Transformer is defective and should be replaced. If the measured voltage is extremely high or low, verify that the AC line input is connected to the proper terminals of the Control Transformer. Refer to Section 9.2 (VOLTAGE CHANGEOVER INSTRUCTIONS)

3. Main board and cell select board connections:

Locate the Main board and Cell Select board on the front panel. Verify the proper connection and polarity of the board and cables.

4. Main board:

If there is the appropriate voltage level across the Control Transformer, disconnect AC power then reapply AC power. This action will reset the microcontroller.

SYMPTOM #2 - POWER IS APPLIED. DISPLAY IS IN IDLE MODE BUT CHARGER WILL NOT START OR CHARGE STARTS BUT IS TERMINATED IMMEDIATELY!

1. Proper battery:

Verify that the number of cells of the battery to be charged matches the charger. Also, check the diagnostic voltage indicators.

2. Good battery:

Measure the total battery voltage. Divide the voltage value measured by the number of battery cells. This will yield an average volts per cell value. If the average volts per cell value is less than 1.7V or greater than 2.8V, then the battery is bad and should not be used.

3. AC & DC fuses:

Disconnect the battery and AC input power from the charger. Verify that the fuses are not open. Replace any defective fuses and check the following:

- Make sure that the battery-to-charger connector cables connect the battery to the charger with the proper polarity.

- Verify that the Terminal Block with Jumpers is correctly configured for the AC input voltage currently being used. If the jumpers are not correctly configured, then go to Section 9.2 (CHANGING AC INPUT LINE VOLTAGES).
- Verify that AC power and battery have been disconnected from the charger. Locate the rectifier diodes on the heatsink. Remove the connecting wires from the diodes. Test the diodes and replace if faulty.
- Make sure all connections are tight.

4. Control transformer:

Apply AC power to the charger and measure the AC voltage across the Control Transformer secondary terminals 8 and 9. The secondary voltage should be approximately 24 V RMS. If there is no voltage measured at the secondary, the Control Transformer is defective and should be replaced. If the voltage measured is extremely high or low, verify the AC input is connected to the proper Control Transformer terminals.

SYMPTOM #3 - CHARGE TERMINATES EARLY

1. High Volts per cell:

If this indicator is on, then the CONTROL measured the average V/cell to be greater than 2.8V.

- Verify that the Battery connected to the charger has the correct number of cells.
- If the battery has the appropriate number of cells, measure the battery voltage. Divide the measured voltage value by the number of battery cells. This value is the average volts per cell of the battery. If the average volts per cell of the battery is between 1.7 and 2.8V/cell, then the battery is good.

2. Low current:

If this indicator is on, the battery on charge was not receiving current.

- Disconnect the battery and AC input power from the charger.
- Check the AC and DC Fuses. Verify that the fuses are not an open circuit. Replace any faulty fuses.
- Verify that the Magnetic Amplifier is not an open circuit. Check for continuity between the Magnetic Amplifier and Cell Select Board. Repair any bad connections. Replace the Magnetic Amplifier if faulty.
- Verify that the AC Resonant Capacitor is not an open circuit. Replace the Capacitor if defective.

3. Charge time exceeded

This indicates that the battery did not reach 80% of full charge within nine hours or that the battery did not charge from 80% charged to full charge within six hours.

Disconnect the battery and AC input power from the charger. Verify that the AC and DC Fuses are not open. Replace any defective fuses.

Verify that the charger and battery Amp-Hour size are matched.

4. Cable disconnection:

The CABLE DISCONNECTION indicator will illuminate whenever the battery-to-charger charging cable is disconnected while the battery is charging. Always make sure to manually shutdown (press the STOP button) the charge before disconnecting the cables.

5. Low Volts per cell:

Having a flashing red SHUTDOWN LED with “Lo U” displayed indicates that the control measured the average volts/cell to be less than 1.7V.

The LOW VOLTAGE condition does not “lock” the charger off since the charger will automatically start charging if the battery’s voltage increases about 1.7V/Cell.

Follow the troubleshooting procedure for High V/Cell.

SECTION 11 SCHEMATICS

See following pages

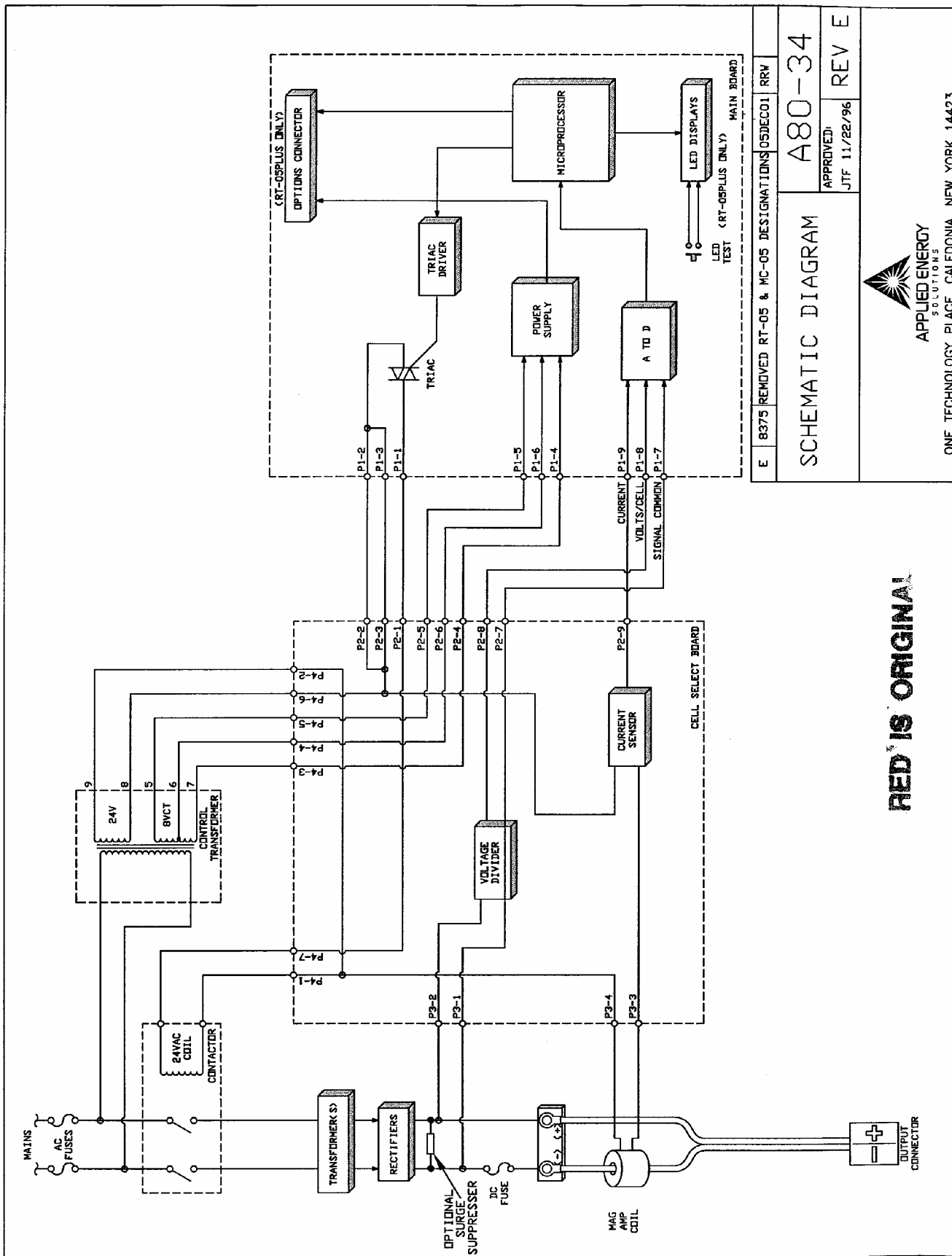

SCHEMATIC DIAGRAM
A80-34

APPROVED:
JTF 11/22/96

REV E

E 8375 REMOVED RT-05 & MC-05 DESIGNATIONS OSDECO1 RRV



RED IS ORIGINAL

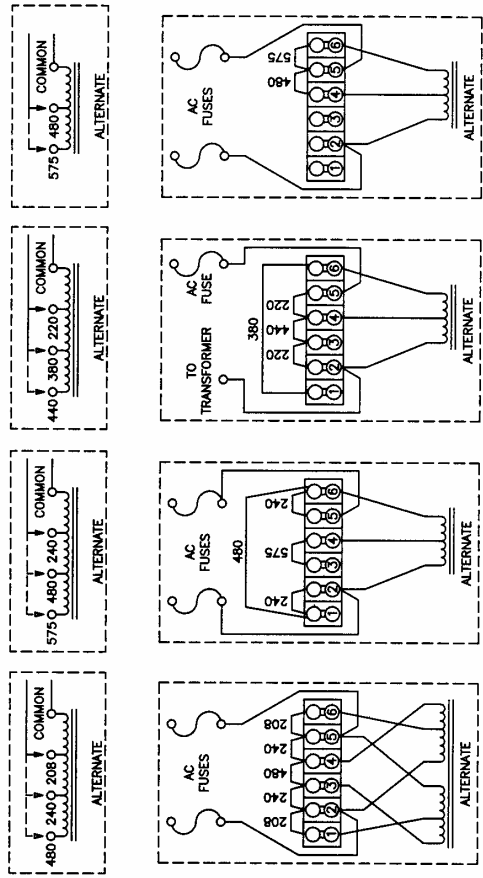
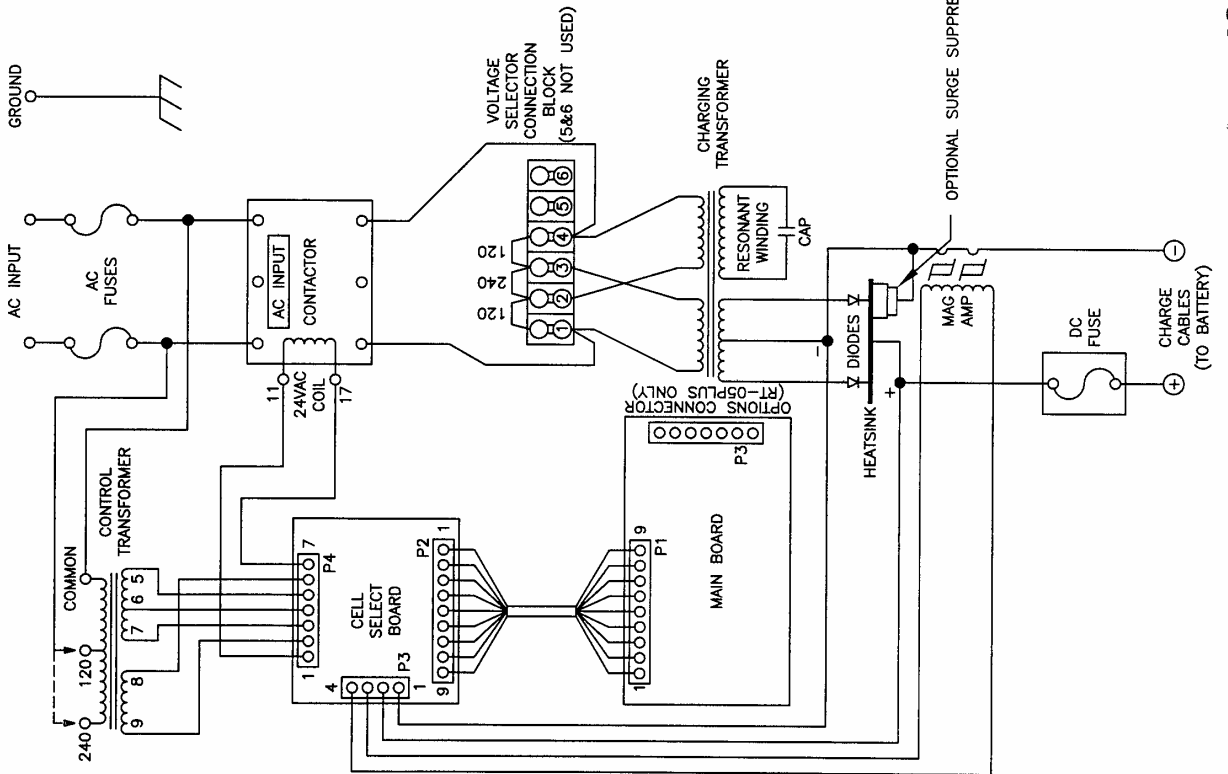

H	8863	VOLTAGE SELECTOR CONNECTION BLOCK WAS 4-POSITION.	15NOV06	JFD	P&M
G	8375	REMOVE RT-05 & MC-05 DESIGNATIONS	05DEC01	RRW	JEB
F	8334	ADDED 480/575 ALTERNATE DIAGRAM	16OCT01	RRW	JEB
E	6795	MOVED DC FUSE TO (+) LEAD	10FEB98	EEB	JTF

SCHEMATIC DIAGRAM
1 PHASE
A80-32
 APPROVED: JTF 1/22/96
 REV H



APPLIED ENERGY SOLUTIONS
 ONE TECHNOLOGY PLACE, CALEDONIA, NEW YORK 14423

RED IS ORIGINAL

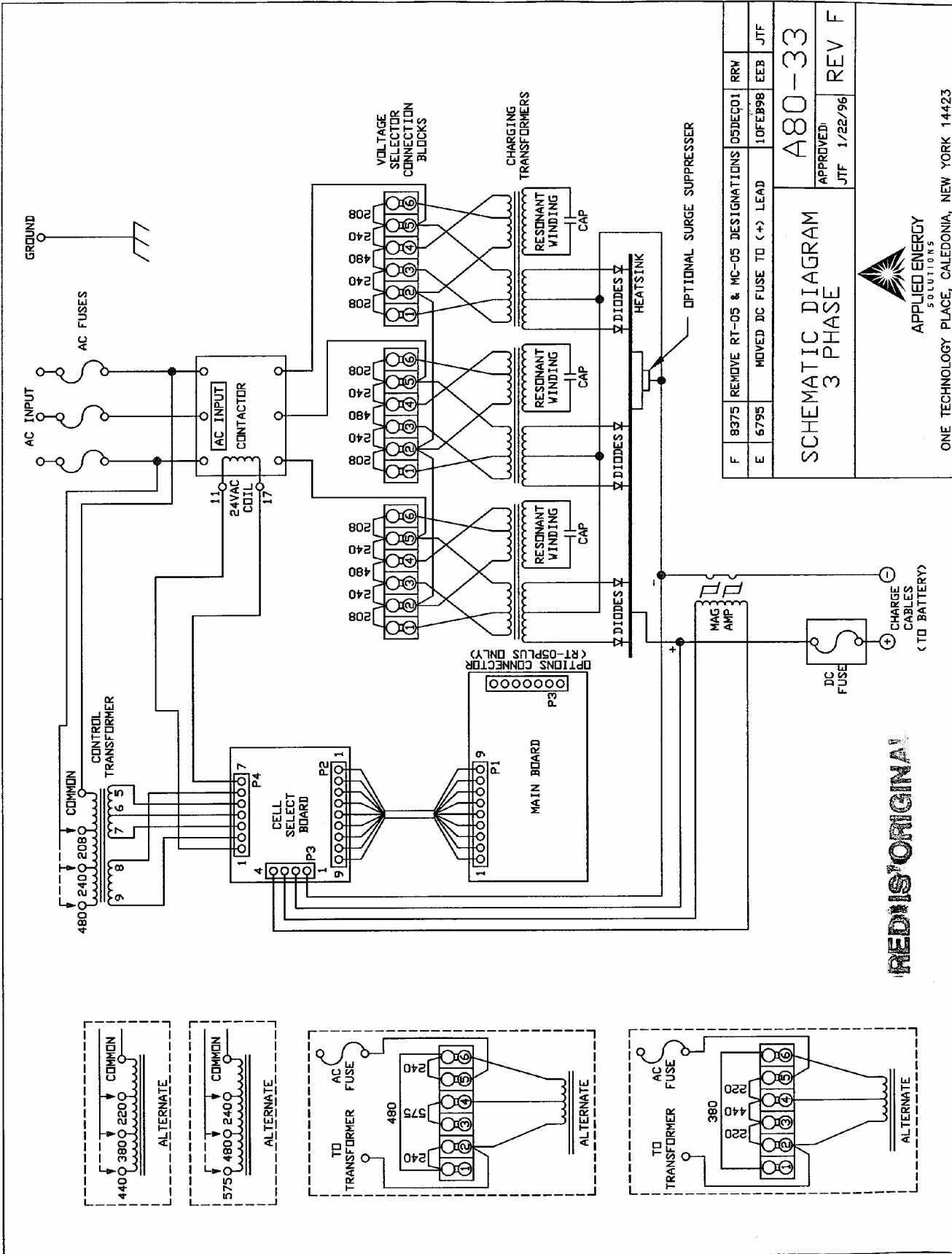

F	8375	REMOVE RT-05 & MC-05 DESIGNATIONS	D5DEC01	RRV
E	6795	MOVED DC FUSE TO (+) LEAD	10FEB98	EEB JTF

A80-33

APPROVED: JTF 1/22/96
REV F

**SCHEMATIC DIAGRAM
3 PHASE**



APPLIED ENERGY SOLUTIONS

ONE TECHNOLOGY PLACE, CALEDONIA, NEW YORK 14423

REDIS ORIGINAL

CHARGER WARRANTY

APPLIED ENERGY SOLUTIONS warrants that each new and unused battery charger manufactured and supplied with good workmanship is free from any known mechanical defect, provided that (A) the product is installed and operated in accordance with the accepted industrial standards and in accordance with the printed instructions furnished by APPLIED ENERGY SOLUTIONS, (B) the product is used under normal conditions for which designed, (C) the product is not used in a corrosive, abnormally dusty or high humidity moisture condensing environment, and (D) the product is not subjected to misuse or negligence, and the product receives proper care, protection and maintenance under supervision of competent personnel.

Warranty Terms and Conditions

APPLIED ENERGY SOLUTIONS WorkHorse 3 Industrial Battery Chargers are warranted for 10 Years⁽¹⁾, which begins on the date of shipment from APPLIED ENERGY SOLUTIONS.

NOTES: ⁽¹⁾Warranty covers parts and labor,

AC fuses and DC fuses are not warranted unless they are found to be defective prior to use.

NON-TRANSFERABLE WARRANTY. This warranty is extended by APPLIED ENERGY SOLUTIONS only to the original user (purchaser) of new equipment from APPLIED ENERGY SOLUTIONS or one of its authorized agents. The product purchased under this agreement shall be used exclusively by the buyer. There shall be no third party beneficiary of this warranty.

REPAIR LIMITATIONS. APPLIED ENERGY SOLUTIONS has the right to site inspection and judgment of the claimed defects in any product covered by this warranty. APPLIED ENERGY SOLUTIONS' liability is limited to the repair of any defects found to exist by APPLIED ENERGY SOLUTIONS or, at APPLIED ENERGY SOLUTIONS' option, the replacement of the defective product.

APPLIED ENERGY SOLUTIONS and its authorized agents shall not be liable for direct or indirect damages in excess of such repair or replacement. In no event shall the purchaser be entitled to recover for contingent expenses from, but not limited to, telephone calls, telegrams, travel expenses, lodging, duties and taxes, labor, rental or replacement equipment, loss of business or profit or other commercial losses.

CONTINUED USE OF DEFECTIVE PRODUCTS. The continued use of an APPLIED ENERGY SOLUTIONS Industrial Battery Charger that is known to be defective VOIDS ALL WARRANTIES.

REPAIR OF MODIFIED EQUIPMENT. Except as authorized in writing the warranty specified does not cover any equipment that has been repaired by any party other than APPLIED ENERGY SOLUTIONS or its authorized agents. Except as authorized in writing the warranty specified does not cover any equipment that has been modified, mechanically or electrically, by any party other than APPLIED ENERGY SOLUTIONS.

WARRANTY EXPENSE LIMITATIONS. APPLIED ENERGY SOLUTIONS will limit the warranty expense of all chargers to be paid at a maximum of the original purchase price of the charger.

The provisions of this warranty shall not apply to product in use outside of the continental USA.

Except as stated above, all other warranties and conditions, either expressed or implied, including implied warranties of merchantability and fitness for a particular purpose, are excluded and buyer assumes all risk and liability resulting from the use of the goods. APPLIED ENERGY SOLUTIONS neither assumes or authorizes any persons to assume for APPLIED ENERGY SOLUTIONS any other liability in connection with the sale or use of the goods sold and there are no oral agreements or warranties collateral to or affecting this written warranty.

When installing, servicing or operating these products, safe practices should be used by skilled and qualified technical persons.