



APPLIED ENERGY
SOLUTIONS

WorkHorse

Series 2

FERRORESONANT BATTERY CHARGERS

Installation and Operating Instructions

Applied Energy Solutions, LLC.
One Technology Place
Caledonia, New York 14423
(585) 538-4421
www.appliedenergysol.com

The Power of Excellence

FM1247
REV D

TABLE OF CONTENTS

SECTION	PAGE
1 IMPORTANT SAFETY INSTRUCTIONS	4
2 RECEIPT AND INSPECTION	5
3 INTRODUCTION	5
4 CONTROL FEATURES	6
5 INSTALLATION	7
6 OPERATING PROCEDURE	9
7 CHARGER CABINETS	12
8 MAINTENANCE	13
9 TROUBLESHOOTING GUIDE	15
10 SCHEMATICS	18

1 IMPORTANT SAFETY INSTRUCTIONS

1. SAVE THESE INSTRUCTIONS. THIS MANUAL CONTAINS IMPORTANT SAFETY AND OPERATING INSTRUCTIONS.
2. WORKING IN THE VICINITY OF A LEAD-ACID BATTERY IS DANGEROUS. BATTERIES GENERATE EXPLOSIVE GASSES DURING NORMAL BATTERY OPERATION. FOR THIS REASON IT IS OF THE UTMOST IMPORTANCE THAT EACH TIME BEFORE USING YOUR CHARGER, YOU READ AND FOLLOW THE INSTRUCTIONS PROVIDED EXACTLY.
3. TO REDUCE RISK OF BATTERY EXPLOSION, FOLLOW THESE INSTRUCTIONS AND THOSE ON THE BATTERY.
4. NEVER SMOKE OR ALLOW AN OPEN SPARK OR FLAME IN THE VICINITY OF THE BATTERY OR ENGINE.
5. USE CHARGER FOR CHARGING A LEAD-ACID BATTERY ONLY. IT IS NOT INTENDED TO SUPPLY POWER TO AN EXTRA LOW-VOLTAGE ELECTRICAL SYSTEM OR TO CHARGE DRY-CELL BATTERIES. CHARGING DRY-CELL BATTERIES MAY CAUSE THEM TO BURST AND CAUSE INJURY TO PERSONS AND DAMAGE TO PROPERTY.
6. NEVER CHARGE A FROZEN BATTERY.
7. DO NOT OPERATE IN A CLOSED-IN AREA OR RESTRICT VENTILATION IN ANY WAY.
8. DANGER: RISK OF ELECTRICAL SHOCK. DO NOT TOUCH UNINSULATED PORTION OF OUTPUT CONNECTOR OR UNINSULATED BATTERY TERMINAL.
9. CAUTION: DISCONNECT SUPPLY BEFORE CHANGING FUSE.

INSTRUCTIONS IMPORTANTES CONCERNANT LA SECURITE

1. CONSERVER CES INSTRUCTIONS. CE MANUEL CONTIENT DES INSTRUCTIONS IMPORTANTES CONCERNANT LA SECURITE ET LE FONCTIONNEMENT.
2. IL EST DANGEREUX DE TRAVAILLER A PROXIMITE D'UNE BATTERIE AU PLOMB. LES BATTERIES PRODUISENT DES GAS EXPLOSIFS EN SERVICE NORMAL. AUSSI EST-IL IMPORTANT DE TOUJOURS RELIRE LES INSTRUCTIONS AVANT D'UTILISER LE CHARGEUR ET DE LES SUIVRE A LA LETTRE.
3. POUR REDUIRE LE RISQUE D'EXPLOSION, LIRE CES INSTRUCTIONS ET CELLES QUI FIGURENT SUR LA BATTERIE.
4. NE JAMAIS FUMER PRES DE LA BATTERIE OU DU MOTEUR ET EVITER TOUTE ETINCELLE OU FLAMME NUE A PROXIMITE DE CES DERNIERS.

5. UTILISER LE CHARGEUR POUR CHARGER UNE BATTERIE AU PLOMB UNIQUEMENT. CE CHARGEUR N'EST PAS CONCU POUR ALIMENTER UN RESEAU ELECTRIQUE TRES BASSE TENSION NI POUR CHARGER DES PILES SECHES. LE FAIT D'UTILISER LE CHARGEUR POUR CHARGER DES PILES SECHES POURRAIT ENTRAINER L'ECLATEMENT DES PILES ET CAUSER DES BLESSURES OU DES COMMAGES.
6. NE JAMAIS CHARGER UNE BATTERIE GELEE.
7. NE PAS FAIRE FONCTIONNER LE CHARGEUR DANS UN ESPACE CLOS ET/OU NE PAS GENER LA VENTILATION.
8. DANGER: RISQUE DE CHOCS ELECTRIQUES. NE PAS TOUCHER LES PARTIES NON ISOLEES DU CONNECTEUR DE SORTIE OU LES BORNES NON ISOLEES DE L'ACCUMULATEUR.
9. ATTENTION: COUPER L'ALIMENTATION AVANT DE REMPLACER LES FUSIBLES.

2 RECEIPT AND INSPECTION

Upon receipt of the charger the information on the shipping carton should be checked against your order. Any discrepancies should be reported to the nearest authorized representative.

Whenever possible, move the charger to the installation site before uncrating. All chargers can be handled with a lift truck by inserting the forks under the bottom of the charger.

Remove the carton and inspect the charger for damage. If there is any damage, save the carton for inspection and notify the carrier immediately.

Check the nameplate and labels against your order and specifications. Any discrepancies should be reported immediately to the nearest authorized representative.

3 INTRODUCTION

SERIES 2 Industrial Battery Chargers are full wave silicon rectified ferroresonant chargers.

Charging current is regulated by the ferroresonant transformer(s). The ferroresonant transformers allow the battery to determine its own charge rate with respect to its state of discharge.

The controllers are custom dv/dt-di/dt termination PCB assemblies for flooded lead-acid battery chargers. A solid state, pre-programmed microcomputer provides total control of charge termination, preventing both undercharging and overcharging. The microcomputer incorporates built-in fault detection to ensure correct battery connection and smooth operation. The charge is terminated automatically when the control determines that the battery is fully charged.

4 CONTROL FEATURES

- Automatic five-second delayed start upon connection of a proper sized, good battery.
- Battery voltage sensing determines if there is a proper sized battery connected to the charger. This prevents charging if there is a bad battery connected, no battery connected, bad battery-to-charger connection or battery voltage and charger mismatch.
- Battery voltage and current are continuously monitored.
- Automatic dv/dt-di/dt charge termination.
- Negative battery slope termination to prevent overcharge/thermal runaway.
- Automatic 12-hour “REFRESH” adds a top off charge to a fully charged battery. The charger will start a “refresh” charge 12 hours after a normal charge complete has been reached, assuming that the battery was not disconnected during that time.
- Backup Timers prevent extended charging of a damaged battery. The first timer starts at the beginning of the charge cycle and runs for 9 hours. At 9 hours, if the battery has not reached the 80% point, the charger will shutdown. The second timer starts at the 80% point and runs for 6 hours. If the charger does not terminate by then it will shutdown.
- Automatic Shutdown Lockout will not allow a charge to start after a manual or problem shutdown occurs. Automatic Shutdown Lockout is cleared after the “Shutdown” battery is disconnected. This allows a charge to begin upon connection of a good, proper sized battery.
- Automatic shutdown occurs for any of five failure conditions:
 - Fault code “Lo U”** – Low volts per cell – the battery voltage is less than 1.7 vpc. The charger will not be “locked off”. The charger will automatically start charging when the battery voltage is greater than 1.7 vpc.
 - Fault code “Hi U”** – High volts per cell – greater than 2.8.
 - Fault code “dISC”** – Battery disconnected from charger during charge.
 - Fault code “dur”** – Charge time exceeded - backup timer expired.
 - Fault code “Lo I”** – Low charging current – charging current less than approximately 3 amps.
- Manual STOP switch - Will stop the charger from charging. The display will indicate “OFF” until the battery is disconnected. When pressed with no battery connected displays the delay start setting.

- One to nine-hour programmable delayed start thumb wheel switch. This rotary switch can be set from 0 to 9 hours to delay the start of charge.
- Optional Automatic Equalization Cycle every 5th cycle. This option is enabled by removing “W1” on the control PC board. For a completed charge cycle to be counted, the battery must be on charge at less than 80% for 1 hour or more from start of charge.
- Equalize switch - This switch when depressed will turn on and off the three hour additional manual equalizing charge. When the Equalize function is turned on, an “E” will be displayed in the leftmost digit of the display. The “E” will flash during the actual equalize charge cycle (manual and automatic). If Auto-Equalize has been selected, pressing this switch prior to connecting the battery will allow the number of charge cycles remaining before auto-equalize cycle to be displayed in the format ‘E-#’.
- LED Indicators:
 - “**CHARGING**” - charger is charging the battery.
 - “**80%**” - the battery voltage is greater than 2.37 volts per cell.
 - “**CHARGE COMPLETE**” - the charge cycle has been terminated normally.
 - “**SHUTDOWN**” - the unit has shut down for a fault.
- 80% Voltage Selection, factory set at 2.37 volts per cell. This may be changed to 2.45 volts per cell by removing “R32” on the PC control board assembly.

5 INSTALLATION

5.1 PHYSICAL LOCATION:

Charging areas should be clean and dry. The temperature of the charging room should be between 32°F (0°C) and 77°F (25°C), with occasional and brief periods of ambient temperature as high as 104°F (40°C). Combustible materials, open flames and smoking should not be permitted in or near the charging room.

WARNING

A BATTERY ON CHARGE WILL EMIT EXPLOSIVE GAS. VENTILATE THE CHARGING ROOM TO PREVENT GAS ACCUMULATION.

5.2 MOUNTING:

The SERIES 2 charger cabinets must be mounted on a surface constructed from non-combustible material, such as stone, brick, concrete or metal. Mounting holes are provided in the frame for securing the charger.

5.3 INPUT POWER CONNECTION:

All chargers are shipped from the factory connected for the input voltage specified on your purchase order. A “STOP” label, located inside the door, indicates the factory set input voltage.

WARNING

VERIFY THAT THE AC ELECTRICAL SERVICE IS DISCONNECTED AT THE BREAKER BEFORE ATTEMPTING TO CONNECT AC POWER TO THE CHARGER.

The AC input terminals are identified by a red-on-white AC INPUT label, located on the side near the fuse block. The AC input cable is to be connected to the proper AC INPUT terminals within the charger cabinet.

The fuse block’s input terminals are rated for 14 AWG to 2 AWG wire. The recommended torque is listed on the fuse block itself.

A green grounding wire is to be connected from the Grounding Terminal within the charger cabinet to the service system ground. The Grounding Terminal is identified by a green-on-white Ground Terminal Label on the charger base. If a system ground is not available, the charger frame must be connected to a driven ground rod in accordance with National and Local electrical codes. Proper application and tight terminal connections are important in avoiding future problems. The ground lug is rated for 14 AWG to 6 AWG wire. The recommended torque setting is shown in Table 5.1.

Table 5.1

Wire Gauge	Recommended Torque Setting
PANDUIT LAMA2-14Q	
6 – 10 AWG	40 in lbs
12 – 14 AWG	15 in lbs
T&B ADR-2	
6 AWG	35 in lbs
8 – 14 AWG	20 in lbs

The charger is normally furnished with an output charge plug or receptacle. Verify that the connectors on both the battery and the charger are correct. Verify that when connected, the positive polarity (red) of the charger is connected to the positive terminal of the battery.

If the charger is to be used at a different AC voltage than presently set for, the charger may be adjusted to operate for the different AC service. Refer to SECTION 8.2 CHANGING THE AC INPUT LINE VOLTAGE.

6 OPERATING PROCEDURE

6.1 PRELIMINARY SET-UP:

Once power has been applied to the charger, a “dash” will sequence across the display on the front panel. This indicates the charger is in the “IDLE MODE” of operation, awaiting a battery connection.

6.2 IMMEDIATE/DELAY START:

The control may be programmed to delay the start of the charge from one to nine hours as well as an immediate start of the charge upon battery to charger connection. Note: all units are shipped from the factory set for immediate start (0-hour delay).

If a power failure occurs, no damage will occur to the battery or the charger. If a battery is still connected when power returns, the control will override any delayed start setting and initialize an immediate start of the charge. Once the charge has been terminated, the delay start will function normally thereafter.

- Remove AC power from the charger.
- Open the charger cabinet door.
- Locate the DELAY START thumb wheel switch behind the front panel at the bottom of the control board. Adjust the DELAY START thumb wheel switch until the NUMBER INDICATOR on the switch yields the desired number of delay hours.
- Close and secure the cabinet door.
- Apply AC power to the charger.
- When a good, proper sized battery is connected to the charger, the display will indicate the amount of time before the charge is initiated, and the control will begin a countdown to charge.

6.3 CHARGING THE BATTERY:

Compare the number of cells and amp-hour capacity of the battery to be charged with the charger rating found on the charger nameplate. The number of cells in the battery to be charged MUST match the nameplate data. The amp-hour ratings should also match for timely charging of the battery. Once the battery to be charged has been determined to match the charger, then connect the battery to the charger. The control will measure the average V/Cell of the connected battery.

If the control has verified the connection of a good battery (between 1.7 and 2.8 V/Cell), the display will show a countdown to charge initialization and the LED's will be flashing. When the countdown reaches zero, the control will turn on the charging transformers.

If the average V/Cell reading is less than 1.7 volts, the display shows “Lo U,” the charge will not begin, and the red SHUTDOWN LED will be flashing. If the average V/Cell is greater than 2.8 volts, the display shows “Hi U,” and the red SHUTDOWN LED will illuminate. Again, the charge will not begin.

Once the charge begins, the display will show the output charging current in amperes. The green CHARGING LED will illuminate. The yellow 80% CHARGED LED will illuminate if the average V/Cell of the battery is greater than 2.37 V/Cell.

6.4 TERMINATION OF CHARGE:

There are three ways in which the charge may be terminated. These three termination methods are, CHARGE COMPLETED TERMINATION, MANUAL TERMINATION and PROBLEM SHUTDOWN TERMINATION.

- CHARGE COMPLETED TERMINATION occurs when a battery reaches full charge. The control monitors the battery charge characteristics. The control utilizes di/dt current compensation to obtain an accurate battery voltage charging slope, dv/dt measurement. Once the control has verified the battery charge slope has reached the pre-determined value for full charge, the charge is terminated automatically. Once the charge is completed and terminated, the green CHARGE COMPLETED LED will illuminate and the display will be in the idle mode.
- MANUAL TERMINATION is accomplished by pressing the STOP push-button switch located on the front panel while charging,

To remove a charging battery from the charger, it is important to press the STOP push-button switch before disconnecting the battery from the charger. Failure to do this may damage the charger.

When the charge has been terminated due to MANUAL TERMINATION, the red SHUTDOWN LED will be on continuously (until the battery is removed). The display will show “OFF”.

- PROBLEM SHUTDOWN

Each PROBLEM SHUTDOWN termination is indicated by a flashing red SHUTDOWN LED and a FAULT code.* After the battery is removed, the red SHUTDOWN LED will remain flashing for one hour. The display indicator will remain on until the battery is disconnected from the charger.

*Refer to Section 4 for a more complete explanation of the diagnostics.

6.5 REFRESH CHARGE:

When a battery remains connected to the charger for 12 hours after the charge has been completed, the control will restart a Refresh charge cycle. The charge rate of the battery will be monitored with $dv/dt-di/dt$ termination occurring typically within 35 minutes. When the charger is in this REFRESH mode the charge amps will be displayed, the CHARGING and 80% CHARGE LED's will be on, and the CHARGE COMPLETE LED will be blinking.

A two-day weekend will have from three to five REFRESH cycles.

6.6 THREE HOUR EQUALIZE CYCLE:

- A 3-hour AUTOMATIC EQUALIZATION cycle will occur every 5th charging cycle when this feature is enabled. A completed cycle is counted only if 1 hour or more time is required to reach 80% charged from charge start. To enable, remove 'W1' on the control PCB.
- The manual equalize button when pushed will provide a timed three hour charge extension after $dv/dt-di/dt$ termination has been reached. It will not reset the automatic equalize counter, if auto-equalize is enabled.

7 CHARGER CABINETS

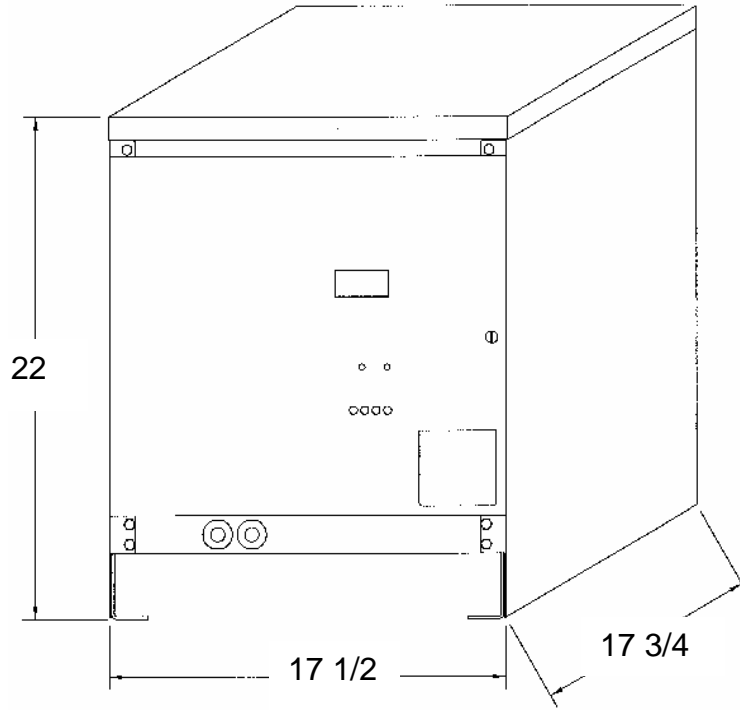

SINGLE PHASE

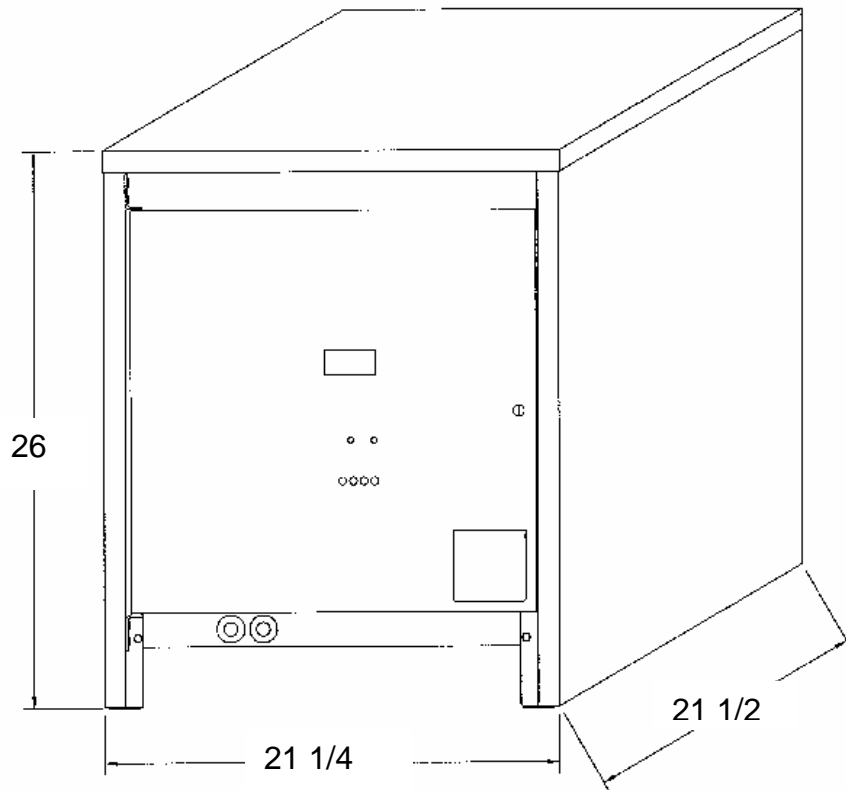

THREE PHASE

8 MAINTENANCE

IMPORTANT

BEFORE PERFORMING ANY MAINTENANCE ON THE CHARGER:

- A) If a battery is being charged, terminate the charge by pressing the STOP button.
- B) Disconnect the battery from the charger.
- C) Remove AC power from the charger.

8.1 MONTHLY PREVENTIVE MAINTENANCE:

WARNING

HIGH VOLTAGES EXIST WITHIN THE CHARGER, WHICH CAN CAUSE SEVERE INJURY OR DEATH. SERVICE SHOULD BE PERFORMED ONLY BY QUALIFIED SERVICE PERSONNEL. IMPROPER SERVICING MAY DAMAGE THE CHARGER.

- If a battery is being charged, terminate the charge by pressing the STOP button.
- Disconnect the battery from the charger.
- Remove AC power from the charger.
- Using compressed air, remove any dust from the inner cabinet walls and internal components of the charger.
- Wipe the exterior of the cabinet and clear any obstructions from the ventilation louvers.
- Make sure that all bolted or screwed electrical connections are tight.
- Make sure that the insulation on all cables and wires is in good condition. Replace if necessary.

8.2 CHARGER ADJUSTMENTS:

CHANGING THE AC INPUT LINE VOLTAGE:

SERIES 2 chargers are designed to operate at different voltage levels. The chargers can be ordered for 208/240/480 volts, 240/480/575 volts, 60 Hz single and three phase or 480/575/600 volts, 60 Hz three phase electric services depending on the charger.

If the charger is to be operated on a different rated input voltage than the ordered value, follow the voltage changeover instructions described below.

VOLTAGE CHANGEOVER INSTRUCTIONS:

- Manually terminate the charging battery by pressing the STOP button and disconnect battery from charger.
- Remove AC power from the charger.

- Locate the TERMINAL BLOCK WITH JUMPERS (one Terminal Block per transformer) and the STOP/CAUTION LABEL (bottom section of label shows various voltage/jumper configurations).
- Change the jumpers in accordance with the STOP/CAUTION label, for the voltage input configuration desired.
- Locate the AC FUSES and FUSE LABEL. Change the fuses to the appropriate value as indicated by the punched holes or values circled on the fuse label.
- Locate the CONTROL TRANSFORMER. Change the primary input connection in accordance with the voltage printed on the transformer and STOP label.
- Change the voltage level on the STOP/CAUTION label to the new voltage level.
- CHECKLIST:
 - Verify that the Terminal Block(s) with Jumpers are configured correctly. Make sure that all Terminal Blocks with Jumpers have been changed properly.
 - Verify the installation of properly rated fuses.
 - Verify that the Control Transformer primary taps have been changed correctly.
 - Verify that the STOP label, located inside the door, has been corrected to the new input voltage level that the charger is set for.
 - Close and secure the cabinet.
 - Connect AC power to the charger.

CHARGING CURRENT START & FINISH RATE ADJUSTMENT:

WARNING

HIGH VOLTAGES EXIST WITHIN THE CHARGER, WHICH CAN CAUSE SEVERE INJURY OR DEATH. SERVICE SHOULD BE PERFORMED ONLY BY QUALIFIED SERVICE PERSONNEL. IMPROPER SERVICING MAY DAMAGE THE CHARGER.

Each of the SERIES 2 Ferroresonant Transformers has one buck-boost winding for the Resonant Capacitor. This allows the charger output current to be adjusted to accommodate variations in the AC line voltage and provides an adjustment of approximately $\pm 8\%$ depending upon connections. NOTE: On three phase units, both transformers must be adjusted to the same tap settings.

Normal Output is with the AC capacitor connected to leads 7 & 8. Leads 9 & 10 are unconnected and insulated.

To increase output, disconnect lead 8 from the AC capacitor and connect to lead 9. Connect lead 10 to AC capacitor where lead 8 originally was connected. Leads 7-10 must be insulated after this adjustment.

To decrease output, disconnect lead 8 from the AC capacitor and connect to lead 10. Connect lead 9 to AC capacitor where lead 8 originally was connected. Leads 7-10 must be insulated after this adjustment.

9 TROUBLESHOOTING GUIDE

This Troubleshooting Guide deals with the SERIES 2 battery chargers. Each section of this guide is further divided into subsections. Each subsection is titled with a symptom. Locate the symptom your charger is experiencing and follow the step by step troubleshooting procedure to determine the cause of the problem (Refer to circuit diagrams of SECTION 10)

SYMPTOM #1 - POWER IS APPLIED BUT THE DISPLAY IS NOT ON!

1. AC POWER CONNECTION:

Make sure the AC input line, located at the AC FUSE BLOCK is connected to the AC power outlet. Measure the voltage and verify that AC power is at the charger.

2. CONTROL TRANSFORMER:

Locate the CONTROL TRANSFORMER. Measure the AC input voltage at the Control Transformer primary. If there is no voltage measured, repair open circuit.

Measure the Control Transformer secondary voltage across terminals 5 and 7. The AC voltage should be approximately (18 to 20) volts rms. If no voltage is measured, then the Control Transformer is defective and should be replaced. If the measured voltage is extremely high or low, verify that the AC line input is connected to the proper terminals of the Control Transformer. (Refer to SECTION 8.2, CHANGING THE AC INPUT LINE VOLTAGE.)

3. MAIN, CELL SELECT CONNECTIONS:

Locate the Main PC board and CELL SELECT PC BOARD on the front panel. Verify the proper connection and polarity of the boards and cables.

4. MAIN BOARD:

If there is the appropriate voltage level across the Control Transformer, disconnect AC power, then reapply AC power. This action will reset the Micro controller.

SYMPTOM #2 - POWER IS APPLIED. DISPLAY IS IN IDLE MODE, BUT CHARGER WILL NOT START – OR - CHARGE STARTS BUT IS TERMINATED IMMEDIATELY!

1. PROPER BATTERY:

Verify that the number of cells of the battery to be charged matches the charger. Also, check the display for fault code (described in Section 4).

2. GOOD BATTERY:

Measure the total battery voltage. Divide the voltage value measured by the number of battery cells. This will yield the average volts per cell value. If the average volts per cell value is less than 1.7 volts or greater than 2.8 volts, then the battery is bad and should not be used.

3. AC & DC FUSES:

Disconnect the battery and AC input power from the charger. Verify that the fuses are not open. Replace any defective fuses and check the following:

- Make sure that the battery-to-charger connector cables connect the battery to the charger with the proper polarity.
- Verify that the Terminal Block With Jumpers is correctly configured for the AC input voltage currently being used. If the jumpers are not correctly configured, go to SECTION 8.2 of this manual, CHANGING AC INPUT LINE VOLTAGES.
- Verify that AC power and battery have been disconnected from the charger. Locate the rectifier diodes on the heatsink. Remove the connecting wires from the diodes. Test the diodes and replace if faulty.
- Make sure all connections are tight.

4. CONTROL TRANSFORMER:

Apply AC power to the charger. Measure the AC voltage across the Control Transformer secondary terminals 8 and 9. The secondary voltage should be approximately 24 volts rms. If there is no voltage measured at the secondary, the Control Transformer is defective and should be replaced. If the voltage measured is extremely high or low, verify that the AC input is connected to the proper Control Transformer terminals.

SYMPTOM #3 - CHARGE TERMINATES EARLY!

1. HIGH VOLTS/CELL (Hi U):

If this indicator is on, then the CONTROL measured the average V/Cell to be greater than 2.8 volts.

- Verify that the Battery connected to the charger has the correct number of cells.
- If the battery has the appropriate number of cells, measure the battery voltage. divide the measured voltage value by the number of battery cells. This value is the average volts per cell of the battery. If the average volts per cell measures between 1.7 and 2.8 V/Cell, then the battery is good.

2. LOW CURRENT (Lo I):

If this indicator is on, the battery on charge was not receiving current.

- Disconnect the battery and AC input power from the charger.
- Check the AC and DC Fuses. Verify that the fuses are not open. Replace any faulty fuses.
- Verify that the Magnetic Amplifier is not an open circuit. Check for continuity between the Magnetic Amplifier and Cell Select Board. Repair any bad connections. Replace the Magnetic Amplifier if faulty.
- Verify that the AC Resonant Capacitor is not an open circuit. Replace the Capacitor if defective.

3. CHARGE TIME EXCEEDED (dur):

This indicates that the battery did not reach 80% of full charge within nine hours or that the battery did not charge from 80% charged to full charge within six hours.

- Disconnect the battery and AC input power from the charger. Verify that the AC and DC Fuses are not open. Replace any defective fuses.
- Verify that the charger and battery AMP-HR size are matched.

4. CABLE DISCONNECTION (dISC):

The CABLE DISCONNECTION indicator will be on whenever the battery-to-charger charging cable is disconnected while the battery is charging. Always make sure to manually shutdown (press the stop button) the charge before disconnecting the cables.

5. LOW VOLTS/CELL (Lo U):

A flashing red SHUTDOWN LED with “Lo U” displayed indicates that the control measured the average V/Cell to be less than 1.7 volts.

The LOW VOLTAGE condition does not “lock” the charger off since the charger will automatically start charging if the battery’s voltage rises above 1.7 V/Cell.

Follow the troubleshooting procedure for High Volts/Cell.

10 SCHEMATICS

NOTES:

1. TO INCREASE OUTPUT CONNECT TERMINALS 8 & 9 TOGETHER, CONNECT CAPACITOR TO TERMINALS 7 & 10.
2. TO DECREASE OUTPUT CONNECT TERMINALS 8 & 10 TOGETHER, CONNECT CAPACITOR TO TERMINALS 7 & 9.

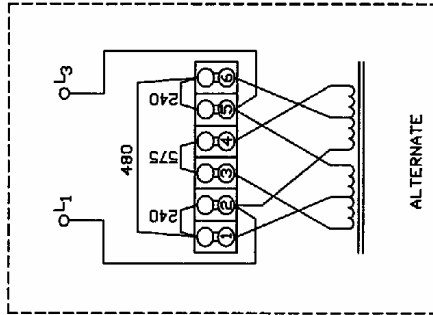
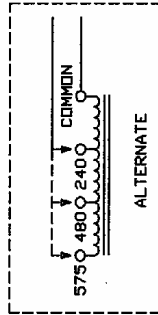
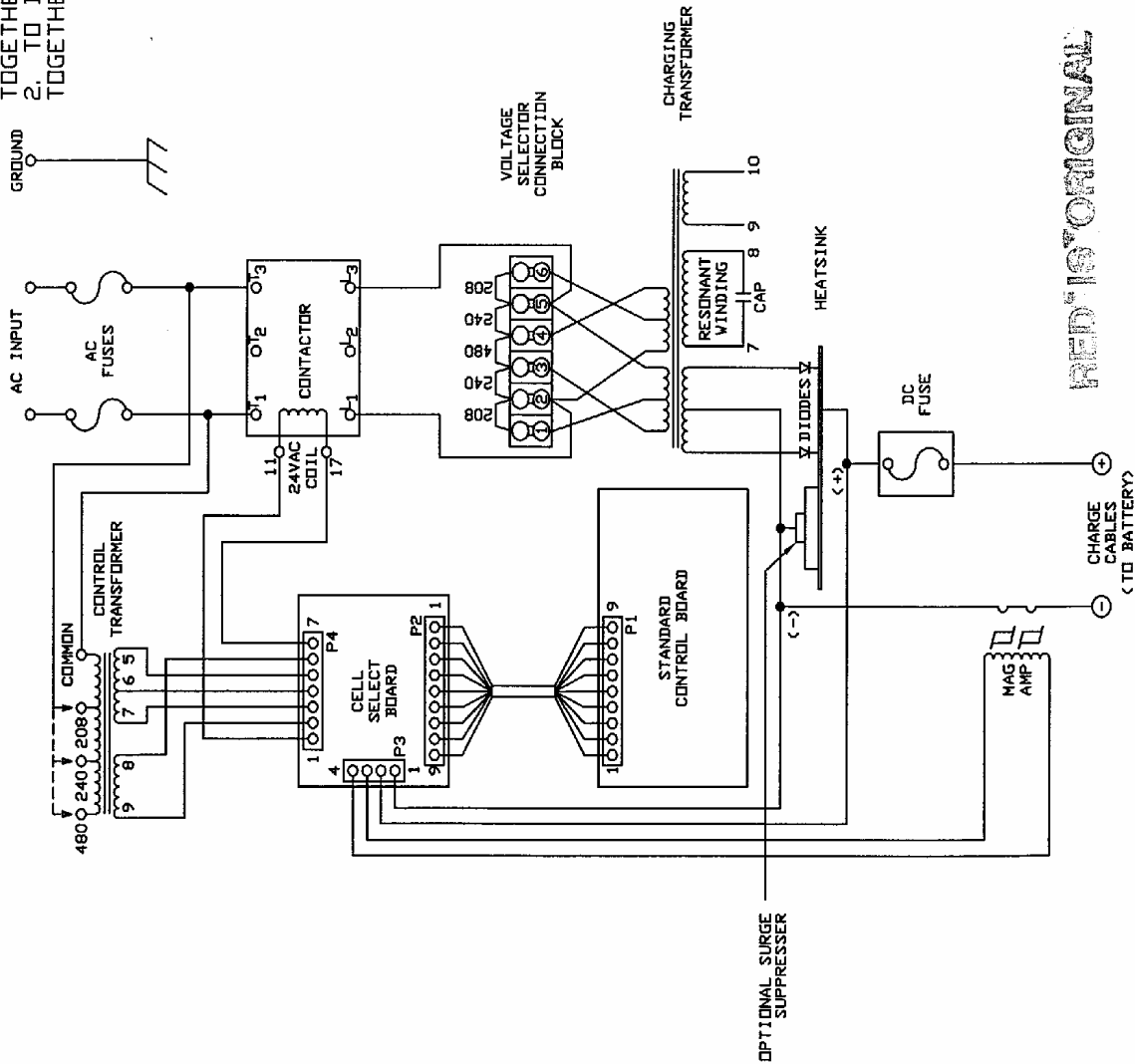

SCHEMATIC DIAGRAM 1 PHASE, WORKHORSE 2	APPROVED:	A80-92 REV -
APPLIED ENERGY SOLUTIONS ONE TECHNOLOGY PLACE, CALEDONIA, NEW YORK 14423		

RED IS ORIGINAL

Intentionally left blank

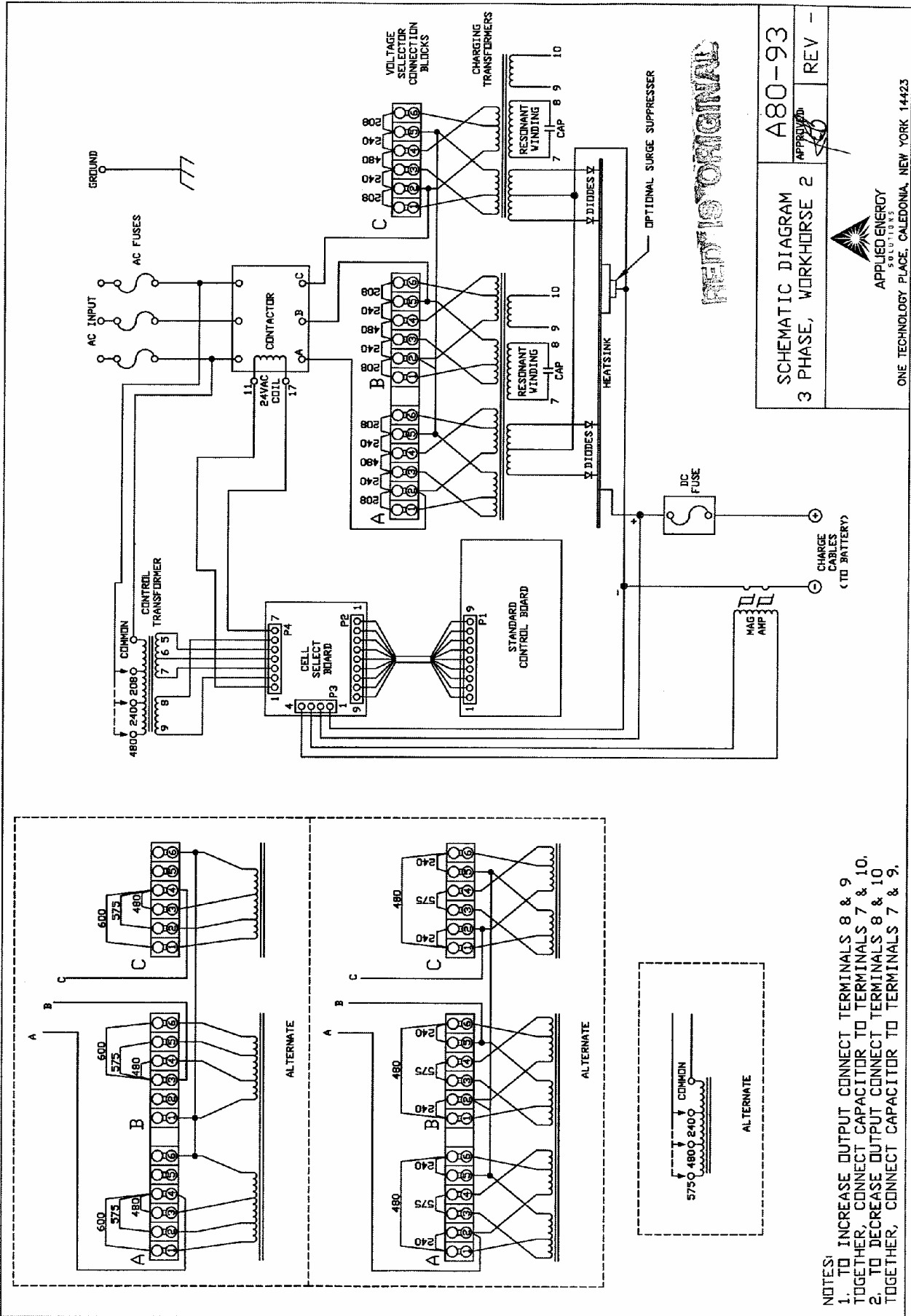

A80-93
 APPROVED
SCHEMATIC DIAGRAM
3 PHASE, WORKHORSE 2
 REV -

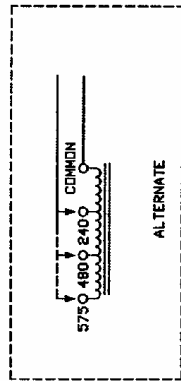
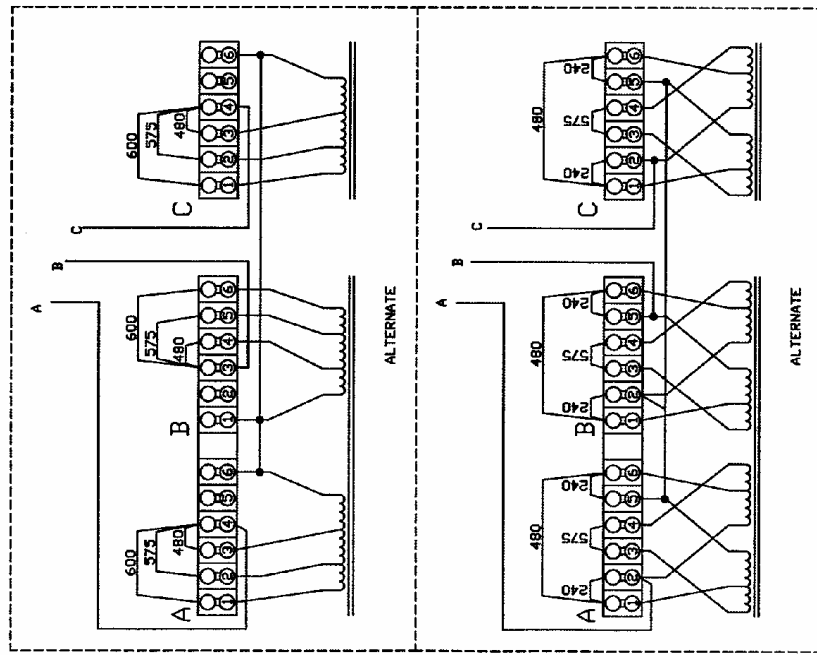
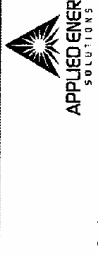

- NOTES:
1. TO INCREASE OUTPUT CONNECT TERMINALS 8 & 9 TOGETHER, CONNECT CAPACITOR TO TERMINALS 7 & 10.
 2. TO DECREASE OUTPUT CONNECT TERMINALS 8 & 10 TOGETHER, CONNECT CAPACITOR TO TERMINALS 7 & 9.

Intentionally left blank

CHARGER WARRANTY

APPLIED ENERGY SOLUTIONS warrants that each new and unused battery charger manufactured and supplied with good workmanship is free from any known mechanical defect, provided that (A) the product is installed and operated in accordance with the accepted industrial standards and in accordance with the printed instructions furnished by APPLIED ENERGY SOLUTIONS, (B) the product is used under normal conditions for which designed, (C) the product is not used in a corrosive, abnormally dusty or high humidity moisture condensing environment, and (D) the product is not subjected to misuse or negligence, and the product receives proper care, protection and maintenance under supervision of competent personnel.

Warranty Terms and Conditions

APPLIED ENERGY SOLUTIONS WorkHorse 2 Industrial Battery Chargers are warranted for 5 Years⁽¹⁾ (10 years on power transformers and diodes)⁽²⁾, which begins on the date of shipment from APPLIED ENERGY SOLUTIONS.

NOTES: ⁽¹⁾Warranty covers parts and labor, ⁽²⁾Warranty covers parts only

AC fuses and DC fuses are not warranted unless they are found to be defective prior to use.

NON-TRANSFERABLE WARRANTY. This warranty is extended by APPLIED ENERGY SOLUTIONS only to the original user (purchaser) of new equipment from APPLIED ENERGY SOLUTIONS or one of its authorized agents. The product purchased under this agreement shall be used exclusively by the buyer. There shall be no third party beneficiary of this warranty.

REPAIR LIMITATIONS. APPLIED ENERGY SOLUTIONS has the right to site inspection and judgment of the claimed defects in any product covered by this warranty. APPLIED ENERGY SOLUTIONS' liability is limited to the repair of any defects found to exist by APPLIED ENERGY SOLUTIONS or, at APPLIED ENERGY SOLUTIONS' option, the replacement of the defective product.

APPLIED ENERGY SOLUTIONS and its authorized agents shall not be liable for direct or indirect damages in excess of such repair or replacement. In no event shall the purchaser be entitled to recover for contingent expenses from, but not limited to, telephone calls, telegrams, travel expenses, lodging, duties and taxes, labor, rental or replacement equipment, loss of business or profit or other commercial losses.

Intentionally left blank

Warranty Terms and Conditions, Continued

CONTINUED USE OF DEFECTIVE PRODUCTS. The continued use of an APPLIED ENERGY SOLUTIONS Industrial Battery Charger that is known to be defective **VOIDS ALL WARRANTIES.**

REPAIR OF MODIFIED EQUIPMENT. Except as authorized in writing the warranty specified does not cover any equipment that has been repaired by any party other than APPLIED ENERGY SOLUTIONS or its authorized agents. Except as authorized in writing the warranty specified does not cover any equipment that has been modified, mechanically or electrically, by any party other than APPLIED ENERGY SOLUTIONS.

WARRANTY EXPENSE LIMITATIONS. APPLIED ENERGY SOLUTIONS will limit the warranty expense of all chargers to be paid at a maximum of the original purchase price of the charger.

The provisions of this warranty shall not apply to product in use outside of the continental USA.

Except as stated above, all other warranties and conditions, either expressed or implied, including implied warranties of merchantability and fitness for a particular purpose, are excluded and buyer assumes all risk and liability resulting from the use of the goods. APPLIED ENERGY SOLUTIONS neither assumes or authorizes any persons to assume for APPLIED ENERGY SOLUTIONS any other liability in connection with the sale or use of the goods sold and there are no oral agreements or warranties collateral to or affecting this written warranty.

When installing, servicing or operating these products, safe practices should be used by skilled and qualified technical persons