

COLT CELL BATTERY CHARGER

Installation and Operating Instructions



INSTALLATION

- All COLT chargers are for indoor use only.
- All COLT chargers are designed for installation into the battery tray.
- Charging areas must be clean, dry and free from combustible materials, and/or open flames.
- Charging areas must be properly ventilated and smoking should never be allowed in or near the charging area.
- The temperature of the charging room should be between 32° F and 104° F.

CAUTION: *To reduce the risk of fire, use only on AC source provided with the appropriate branch circuit protection listed in Table 1 and per the NATIONAL ELECTRIC CODE ANSI/NFPA. Battery charging products can cause serious injury, death and/or damage to other equipment and property if the safety rules are not strictly followed.*

MODELS:

All models except A15730 and A15731 are equipped with one connector that must be mated with the battery connector before charging takes place. The direct-connect models A15730 and A15731 are equipped with an additional connector, which is connected to the truck for enhanced charging convenience.

COLT CHARGER CONTROL FEATURES

- Automatic five-second delayed start upon connection of battery. Voltage is checked for the correct number of cells. The display will countdown from 9 to 0 and two LED's will be alternately flashing red and green.
- Soft start current ramp-up.
- Battery voltage and current are continually monitored and controlled.
- Four charge profiles for Gelled, Absorbed Electrolyte (AGM) and Flooded batteries can be selected via DIPswitch setting (see Table 1).
- 80% charge point can be set for cold storage application (consult factory for setting)
- Microprocessor controlled charge termination.
- Equalize switch provided to extend charge 3 additional hours after normal charge termination.
- Automatic fault shut down: displayed numerically on the 2-digit LED readout:
 - Fault code 0** - Manual stop button - used to end the charging process.
 - Fault code 1** - Low volts per cell - less than 1.5 V/Cell.
 - Fault code 2** - High volts per cell - greater than 2.70 or 2.80 V/Cell (set with 80% point).
 - Fault code 3** - Battery disconnected from charger during charge.
 - Fault code 4** - Charge time exceeded - When the battery does not reach the gassing voltage within 16 hours.
 - Fault code 5** - Low charging current - charging current less than approximately 2 Amps.
- Refresh cycle - The charger will start charging at the finish rate current for 30 minutes every time the charger is left connected to a fully charged battery for 24 hours (Flooded profile only).

FM1252
REV C

- Displays:
 - Two-digit LED readout - displays charging current and fault codes.
 - CHARGE STATUS LED: GREEN when unit is charging, RED when the 80% point has been reached, OFF when charge has been completed.
 - DIAGNOSTICS LED: FLASHES RED when a fault has occurred, CONTINUOUS GREEN when set to Equalize, and FLASHES GREEN when Equalizing.
- External Control Buttons
 - STOP Button - Press to stop the charger from charging prior to disconnecting the battery.
 - EQUALIZE Button - Press to add an equalizing charge to the battery. This function only operates when the battery is on charge. Press again to cancel.

PROGRAMMING PROCEDURE

The charger is programmed at the factory per order. However, if any changes are required, use DIPswitches SW3 located on the control board referring to Table 1.

1. To select the desired charge profile, use SW3-1 and 2.
2. To select the battery capacity, use SW3-3 and 4.

NOTE: THE MAX AMP HR RATING OF THE CHARGER CANNOT BE SET ABOVE ITS MAX RATING. For example, 380 Amp-Hour models cannot be set to charge at the 450 Amp Hr or higher rating.

OPERATING PROCEDURE

1. Connect the charger to AC source. A "0" (zero) will scroll across the LED display.
2. Plug the battery connector into the charger receptacle. The charger's 2 LED's will flash and the display will count down from 9 to 0. The charger will start charging and display the charging current on the digital LED display.
3. The charger will automatically turn off upon completion of charge unless the EQUALIZE button is pressed or a fault condition occurs. After a normal charge completion, the charger will return to displaying the sequencing "0". The battery can now be safely unplugged since all charging has stopped.
4. If the battery is needed prior to completion of the charge cycle, press the STOP button and then unplug the power cord. **Do not unplug the power cord while unit is charging.**

STANDARD MODELS

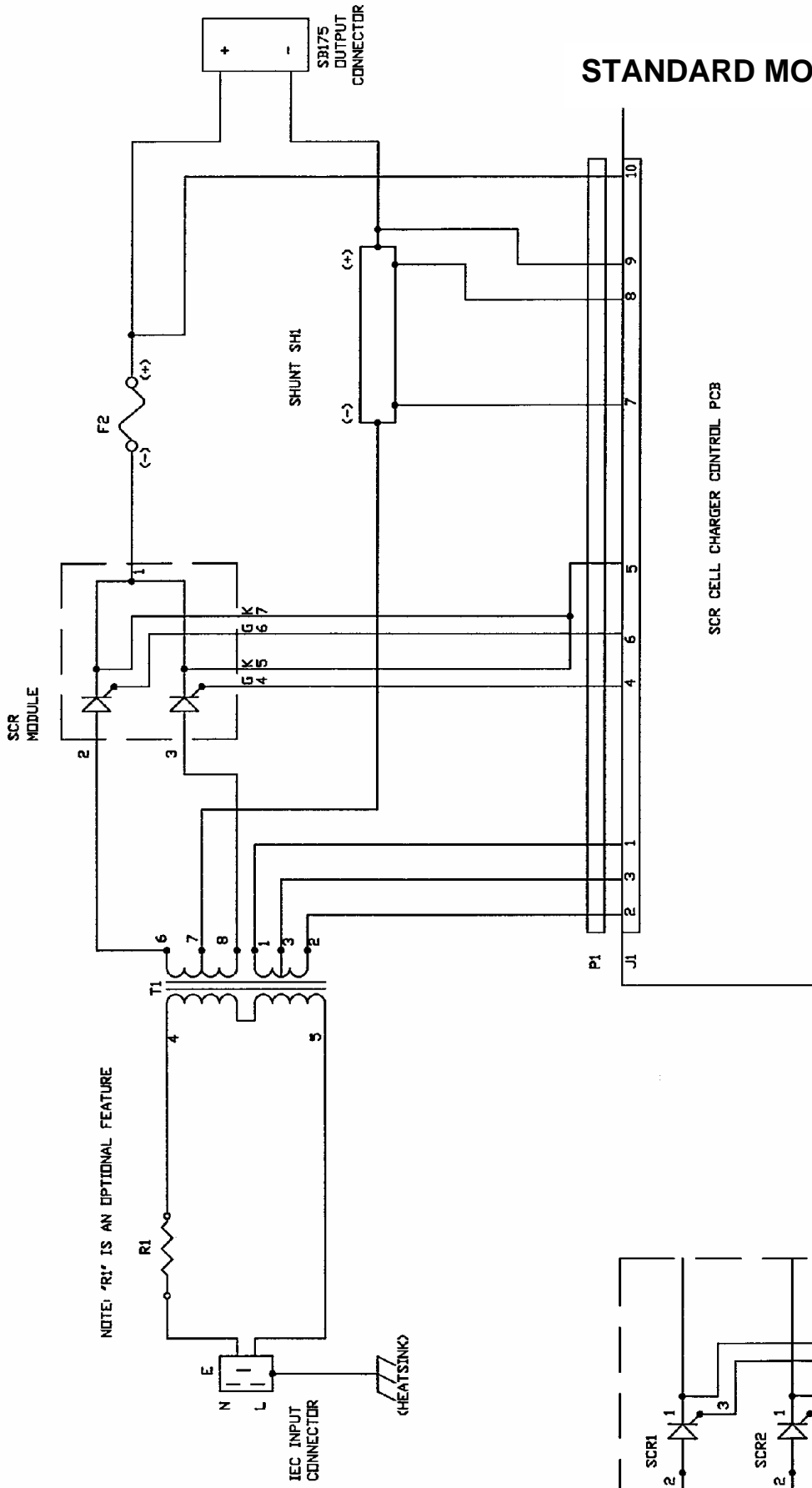

NOTE: 'R1' IS AN OPTIONAL FEATURE

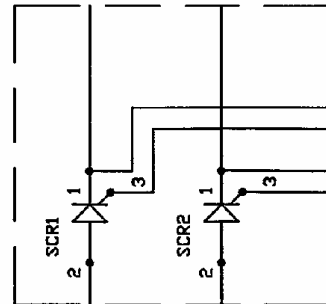

ALTERNATE (15A VERSION)

A15730 & A15731

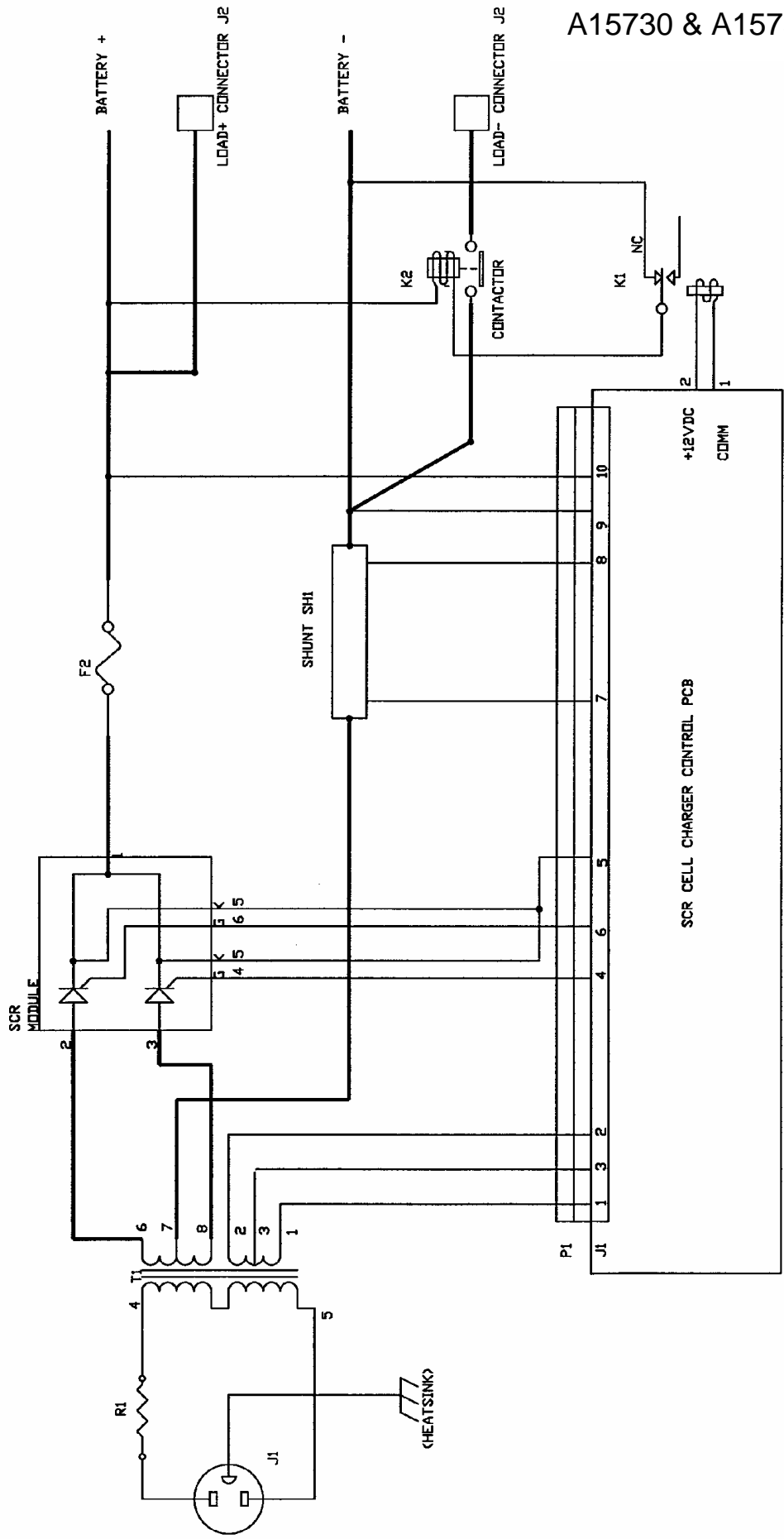
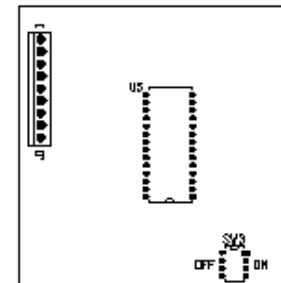

Table 1 COLT CHARGER PRODUCT LINE MODEL NUMBERS AND SPECIFICATIONS

CHARGE PROFILE	BATTERY CAPACITY (AH)	HIGH RATE CURRENT (A)	GASSING VOLTAGE (V/Cell)	FINISH RATE CURRENT (A)	FINISH RATE TIMER (Hrs)	24V 180AH A15229 A15563	24V 380AH A15124 A15573	24V 450AH A15642 A15730	24V 510AH A15125 A15731	12V 600AH A15123	SW3 -1	SW3 -2	SW3 -3	SW3 -4	
BRANCH CIRCUIT PROTECTION REQUIRED						15 A	15 A	15 A	20 A	15 A					
GEL 1 (similar to Deka profile)	180	15	2.33	-	6	D	-	-	-	-	OFF	OFF	N/A	N/A	
	225	16				-	D2	D2	D2	D2	D2	OFF	OFF	OFF	OFF
	380	20				-	D3	D3	D3	D3	D3	OFF	OFF	OFF	ON
	450	25				-	-	D4	-	-	-	OFF	OFF	ON	OFF
	510	32				-	-	-	D5	D5	D5	OFF	OFF	ON	OFF
	600	40				-	-	-	-	D6	D6	OFF	OFF	ON	ON
GEL 2 (similar to Exide profile)	180	15	2.4	3	6	E	-	-	-	-	ON	OFF	N/A	N/A	
	260	20		4		-	E2	E2	E2	E2	E2	ON	OFF	OFF	OFF
	380	25		6		-	E3	E3	E3	E3	E3	ON	OFF	OFF	ON
	450	32		7		-	-	E4	-	-	-	ON	OFF	ON	OFF
	510	40		8		-	-	-	E5	E5	E5	ON	OFF	ON	OFF
	600	45		9		-	-	-	-	E6	E6	ON	OFF	ON	ON
AGM (similar to GNB profile)	180	15	2.35	6	3	G	-	-	-	-	OFF	ON	N/A	N/A	
	260	25		7		-	G2	G2	G2	G2	G2	OFF	ON	OFF	OFF
	380	25		11		-	G3	G3	G3	G3	G3	OFF	ON	OFF	ON
	450	32		13		-	-	G4	-	-	-	OFF	ON	ON	OFF
	510	40		15		-	-	-	G5	G5	G5	OFF	ON	ON	OFF
	600	45		18		-	-	-	-	G6	G6	OFF	ON	ON	ON
FLOODED	180	15	2.37 or 2.45	7	3	F	-	-	-	-	ON	ON	N/A	N/A	
	260	20		11		-	F2	F2	F2	F2	F2	ON	ON	OFF	OFF
	380	25		16		-	F3	F3	F3	F3	F3	ON	ON	OFF	ON
	450	32		19		-	-	F4	-	-	-	ON	ON	ON	OFF
	510	40		22		-	-	-	F5	F5	F5	ON	ON	ON	OFF
	600	45		25		-	-	-	-	F6	F6	ON	ON	ON	ON



APPLIED ENERGY SOLUTIONS, LLC.
 ONE TECHNOLOGY PLACE
 CALEDONIA, NEW YORK 14423
 (585) 538-4421

CHARGER WARRANTY

APPLIED ENERGY SOLUTIONS warrants that each new and unused battery charger manufactured and supplied with good workmanship is free from any known mechanical defect, provided that (A) the product is installed and operated in accordance with the accepted industrial standards and in accordance with the printed instructions furnished by APPLIED ENERGY SOLUTIONS, (B) the product is used under normal conditions for which designed, (C) the product is not used in a corrosive, abnormally dusty or high humidity moisture condensing environment, and (D) the product is not subjected to misuse or negligence, and the product receives proper care, protection and maintenance under supervision of competent personnel.

Warranty Terms and Conditions

APPLIED ENERGY SOLUTIONS Colt Industrial Battery Chargers are warranted for 1 Year⁽¹⁾ (3 years on power transformer and SCR)⁽²⁾, which begins on the date of shipment from APPLIED ENERGY SOLUTIONS.

NOTES: ⁽¹⁾Warranty covers parts and labor, ⁽²⁾Warranty covers parts only
AC fuses and DC fuses are not warranted unless they are found to be defective prior to use.

NON-TRANSFERABLE WARRANTY. This warranty is extended by APPLIED ENERGY SOLUTIONS only to the original user (purchaser) of new equipment from APPLIED ENERGY SOLUTIONS or one of its authorized agents. The product purchased under this agreement shall be used exclusively by the buyer. There shall be no third party beneficiary of this warranty.

REPAIR LIMITATIONS. APPLIED ENERGY SOLUTIONS has the right to site inspection and judgment of the claimed defects in any product covered by this warranty. APPLIED ENERGY SOLUTIONS' liability is limited to the repair of any defects found to exist by APPLIED ENERGY SOLUTIONS or, at APPLIED ENERGY SOLUTIONS' option, the replacement of the defective product.

APPLIED ENERGY SOLUTIONS and its authorized agents shall not be liable for direct or indirect damages in excess of such repair or replacement. In no event shall the purchaser be entitled to recover for contingent expenses from, but not limited to, telephone calls, telegrams, travel expenses, lodging, duties and taxes, labor, rental or replacement equipment, loss of business or profit or other commercial losses.

CONTINUED USE OF DEFECTIVE PRODUCTS. The continued use of an APPLIED ENERGY SOLUTIONS Industrial Battery Charger that is known to be defective VOIDS ALL WARRANTIES.

REPAIR OF MODIFIED EQUIPMENT. Except as authorized in writing the warranty specified does not cover any equipment that has been repaired by any party other than APPLIED ENERGY SOLUTIONS or its authorized agents. Except as authorized in writing the warranty specified does not cover any equipment that has been modified, mechanically or electrically, by any party other than APPLIED ENERGY SOLUTIONS.

WARRANTY EXPENSE LIMITATIONS. APPLIED ENERGY SOLUTIONS will limit the warranty expense of all chargers to be paid at a maximum of the original purchase price of the charger.

The provisions of this warranty shall not apply to product in use outside of the continental USA.

Except as stated above, all other warranties and conditions, either expressed or implied, including implied warranties of merchantability and fitness for a particular purpose, are excluded and buyer assumes all risk and liability resulting from the use of the goods. APPLIED ENERGY SOLUTIONS neither assumes or authorizes any persons to assume for APPLIED ENERGY SOLUTIONS any other liability in connection with the sale or use of the goods sold and there are no oral agreements or warranties collateral to or affecting this written warranty.

When installing, servicing or operating these products, safe practices should be used by skilled and qualified technical persons.