

# QuarterHorse

Opportunity Charger  
with TCC 2.0 Controller

Installation and Operating Instructions



**APPLIED ENERGY**  
SOLUTIONS

One Technology Place  
Caledonia, NY 14423  
(585) 538 – 4421  
[www.appliedenergysol.com](http://www.appliedenergysol.com)

*The Power of Excellence*

FM1317  
REV A



**TABLE OF CONTENTS**

SECTION 1	SAFETY INSTRUCTIONS.....	3
SECTION 2	RECEIPT AND INSPECTION OF THE CHARGER .....	4
SECTION 3	INTRODUCTION .....	4
SECTION 4	CONTROL FEATURES.....	5
SECTION 5	INSTALLATION.....	6
SECTION 6	SETUP MODE.....	8
SECTION 7	REVIEW MODE (PRIOR TO CHARGE ONLY).....	9
SECTION 8	CHARGING MODE .....	10
SECTION 9	FAILURE MODE.....	14
SECTION 10	CHARGER CABINET .....	15
SECTION 11	MONTHLY PREVENTIVE MAINTENANCE .....	15
SECTION 12	TROUBLESHOOTING GUIDE .....	18
SECTION 13	SCHEMATICS .....	19

**SECTION 1****SAFETY INSTRUCTIONS****IMPORTANT SAFETY INSTRUCTIONS**

1. SAVE THESE INSTRUCTIONS. THIS MANUAL CONTAINS IMPORTANT SAFETY AND OPERATING INSTRUCTIONS.
2. WORKING IN THE VICINITY OF A LEAD-ACID BATTERY IS DANGEROUS. BATTERIES GENERATE EXPLOSIVE GASSES DURING NORMAL BATTERY OPERATION. FOR THIS REASON IT IS OF THE UTMOST IMPORTANCE THAT EACH TIME BEFORE USING YOUR CHARGER, YOU READ AND FOLLOW THE INSTRUCTIONS PROVIDED EXACTLY.
3. TO REDUCE RISK OF BATTERY EXPLOSION, FOLLOW THESE INSTRUCTIONS AND THOSE ON THE BATTERY.
4. NEVER SMOKE OR ALLOW AN OPEN SPARK OR FLAME IN THE VICINITY OF THE BATTERY OR ENGINE.
5. USE CHARGER FOR CHARGING A LEAD-ACID BATTERY ONLY. IT IS NOT INTENDED TO SUPPLY POWER TO AN EXTRA LOW-VOLTAGE ELECTRICAL SYSTEM OR TO CHARGE DRY-CELL BATTERIES. CHARGING DRY-CELL BATTERIES MAY CAUSE THEM TO BURST AND CAUSE INJURY TO PERSONS AND DAMAGE TO PROPERTY.
6. NEVER CHARGE A FROZEN BATTERY.
7. DO NOT OPERATE IN A CLOSED-IN AREA OR RESTRICT VENTILATION IN ANY WAY.
8. DANGER: RISK OF ELECTRICAL SHOCK. DO NOT TOUCH UNINSULATED PORTION OF OUTPUT CONNECTOR OR UNINSULATED BATTERY TERMINAL.
9. CAUTION: DISCONNECT SUPPLY BEFORE CHANGING FUSE.

**INSTRUCTIONS IMPORTANTES CONCERNANT LA SECURITE**

1. CONSERVER CES INSTRUCTIONS. CE MANUEL CONTIENT DES INSTRUCTIONS IMPORTANTES CONCERNANT LA SECURITE ET LE FONCTIONNEMENT.
2. IL EST DANGEREUX DE TRAVAILLER A PROXIMITE D'UNE BATTERIE AU PLOMB. LES BATTERIES PRODUISENT DES GAS EXPLOSIFS EN SERVICE NORMAL. AUSSI EST-IL IMPORTANT DE TOUJOURS RELIRE LES INSTRUCTIONS AVANT D'UTILISER LE CHARGEUR ET DE LES SUIVRE A LA LETTRE.
3. POUR REDUIRE LE RISQUE D'EXPLOSION, LIRE CES INSTRUCTIONS ET CELLES QUI FIGURENT SUR LA BATTERIE.
4. NE JAMAIS FUMER PRES DE LA BATTERIE OU DU MOTEUR ET EVITER TOUTE ETINCELLE OU FLAMME NUE A PROXIMITE DE CES DERNIERS.
5. UTILISER LE CHARGEUR POUR CHARGER UNE BATTERIE AU PLOMB UNIQUEMENT. CE CHARGEUR N'EST PAS CONCU POUR ALIMENTER UN RESEAU ELECTRIQUE TRES BASSE TENSION NI POUR CHARGER DES PILES SECHES. LE FAIT D'UTILISER LE CHARGEUR POUR CHARGER DES PILES SECHES POURRAIT ENTRAINER L'ECLATEMENT DES PILES ET CAUSER DES BLESSURES OU DES COMMAGES.
6. NE JAMAIS CHARGER UNE BATTERIE GELEE.
7. NE PAS FAIRE FONCTIONNER LE CHARGEUR DANS UN ESPACE CLOS ET/OU NE PAS GENER LA VENTILATION.
8. DANGER: RISQUE DE CHOCS ELECTRIQUES. NE PAS TOUCHER LES PARTIES NON ISOLEES DU CONNECTEUR DE SORTIE OU LES BORNES NON ISOLEES DE L'ACCUMULATEUR.
9. ATTENTION: COUPER L'ALIMENTATION AVANT DE REMPLACER LES FUSIBLES.



## SECTION 4 CONTROL FEATURES

- 25% recharge in one hour, 80% recharge in approximately three hours and 100% recharge in approximately six hours.
- No battery modifications are required
- Easy access for programming all features
- User selectable features:
  - Charge rate of 18 or 25A/100Ah
  - Delayed start from 30 minutes to four hours, in 15 minute intervals
  - Equalize can be selected manually, automatically with day/time setting, or every 5 cycles
  - Gassing point options: 2.37VPC (default), 2.40VPC, 2.42VPC, and 2.45VPC
  - Automatic refresh charge every 24 hours
  - Programmable charge block out time
  - Programmable charge termination when battery voltage reaches the gassing point, to prevent excessive gassing
- Low electrical noise superior in applications with other electrical equipment and controls
- Remote Control Interface
- Auto start with five second delay
- Automatic shutdown for the following conditions:
  - 80% or final charge exceeds time limit
  - Volts per cell outside safe limits
  - Charging current too high or too low
  - Maximum battery temperature exceeded (requires optional battery temperature sensor)
- Controlled Ferro resonant technology for Total Charge Control over the complete charging cycle
- Digital readout displays:
  - Time remaining to 80% & full charge
  - Charge current/voltage
  - Equalize in process
  - Charge data 25 cycles (time, AH returned, and voltage)
  - Charger setup
  - Fault codes
- LED charge status indicators
  - Gas gauge
  - Charging
  - 80% Charged
  - Charge Complete
  - Equalize
  - Fault Shutdown
- Cool down time displayed
- Manual jump start for over-discharged batteries

## SECTION 5 INSTALLATION

### 5.1 PHYSICAL LOCATION:

Charging areas should be clean and dry. The temperature of the charging room should be between 32°F (0°C) and 104°F (40°C). Combustible materials, open flames and smoking must not be permitted near or in the charging area.

### 5.2 MOUNTING:

The QuarterHorse charger cabinets must be mounted on a surface constructed from non-combustible material, such as stone, brick, concrete or metal. Mounting holes are provided in the frame for securing the charger.

### 5.3 INPUT POWER CONNECTION:

**THE QUARTERHORSE THREE PHASE CHARGERS ARE PHASE ROTATION SENSITIVE; PLEASE ENSURE THAT CLOCKWISE PHASE ROTATION IS OBSERVED.**

The QuarterHorse chargers are shipped from the factory connected for the input voltage specified on your purchase order. A "STOP/CAUTION" label, located inside the door, indicates the factory set input voltage.

**WARNING**  
 VERIFY THE AC ELECTRICAL SERVICE IS DISCONNECTED AT THE SOURCE  
 BEFORE ATTEMPTING TO CONNECT AC POWER TO THE CHARGER.

The AC input terminals are identified by a red-on-white AC INPUT label, located on the base near the fuse block. The AC input cable is to be connected to the proper AC INPUT terminals within the charger cabinet.

The fuse block's input terminals are rated for 14 awg to 2 awg wire. The recommended torque is listed on the fuse block itself.

A grounding wire (bare, green or green with yellow stripe) is to be connected from the Grounding Terminal within the charger cabinet to the service system ground. The Grounding Terminal is identified by a green-on-white Ground Terminal Label on the charger base. If a system ground is not available, the charger frame must be connected to a driven ground rod, in accordance with National and Local electrical codes. Proper application and tight terminal connections are important in avoiding future problems. The ground terminal is rated for 14 awg to 6 awg wire. The recommended torque setting is shown in Table 5.3

Table 5.3.1

Wire Gauge	Recommended Torque Setting
PANDUIT LAMA6-14Q	
6 – 10 AWG	40 in lbs
12 – 14 AWG	15 in lbs
T&B ADR6	
6 AWG	35 in lbs
8 – 14 AWG	20 in lbs

#### 5.4 TEMPERATURE SENSOR INSTALLATION (OPTIONAL)

The battery temperature sensor kit (KT1109/SBX or KT1150/EBC) is designed for use with QuarterHorse Chargers. It senses the battery electrolyte temperature and provides the temperature information to the charger control module. Refer to manual FM1299 for installation details.

#### 5.5 SETTING CHARGER DIP SWITCHES (FOR FIELD REPLACEMENT ONLY)

The QuarterHorse battery chargers are equipped with switches on the main control board that are programmed to the charger specifications. **Care must be used when changing the switch settings as incorrect settings can undercharge, overcharge or damage the battery and / or charger.**

Table 5.5.1

Charger Amp-Hour Rating (AH)	S1-1	S1-2	S1-3	S1-4
260	OFF	OFF	OFF	OFF
380	ON	OFF	OFF	OFF
425	OFF	ON	OFF	OFF
475	ON	ON	OFF	OFF
510	OFF	OFF	ON	OFF
540	ON	OFF	ON	OFF
600	OFF	ON	ON	OFF
680	ON	ON	ON	OFF
750	OFF	OFF	OFF	ON
765	ON	OFF	OFF	ON
865	OFF	ON	OFF	ON
965	ON	ON	OFF	ON
1050	OFF	OFF	ON	ON
1190	ON	OFF	ON	ON
1360	OFF	ON	ON	ON
1450	ON	ON	ON	ON

Table 5.5.2

Charger Cell Count	S1-5	S1-6	S1-7
6	OFF	OFF	OFF
9	ON	OFF	OFF
12	OFF	ON	OFF
18	ON	ON	OFF
24	OFF	OFF	ON
36	ON	OFF	ON
40	OFF	ON	ON
48	ON	ON	ON

Table 5.5.3

Output Cable Length (ft.)	S2-1	S2-2
10 / 15	OFF	OFF
20 / 25	ON	OFF
30 / 35	OFF	ON
40 / 45	ON	ON

## SECTION 6 SETUP MODE

Most programming features are accessible from the front panel. Setup mode is password protected. All setting parameters are saved in the memory and the power rest does not affect the setting. Press and hold “ENTER” for 5 seconds to enter the Setup Mode. Press and hold “ENTER” 5 seconds again to exit the Setup Mode. The display will automatically return to Charger Ready Mode in one minute if no activities are detected.

Press *Data▲* or *Data▼* to change between menus, increment/decrement the values or toggle yes/no.

Press *Enter* to go to the sub menu, proceed to the next sub-menu or save the setting.

Press ◀*Equalize* or *Stop▶* to select the digit to be changed

### 6.1 SETUP PROCEDURES

Password is required to enter the setup mode. The factory set password for the first time setup is “123”. The user can enter the setup mode using this then change the password. If an incorrect password is entered, the display returns to “000”. Use *Data▲*, *Data▼*, ◀*Equalize* and *Stop▶* to change the password. Write the new password down and keep it in a safe place.

Table 6.1.1

Press DATA▲ or DATA▼ to select the menu	Review Menu Description	Press ◀Equalize or Stop▶: to select the digit Press Data▲ or Data▼: to change the values or settings
CLOCK	Clock Setting	DD:HH:MM - MM:DD:YY
80 OFF	Charger Turns Off at Gassing Point Disabled/Enabled	YES NO
FULLCH	Full Charge Period	T ON - DD:HH:MM ...
BLKOUT	Block out Timer Disabled/Enabled	YES NO
BLOCK	Block out Timer Setting	T OFF - DD:HH:MM ...
EQUAL	Auto Equalize	NO EQU 5 CYL TIMED Press ENTER DD HH:MM
DLY ST	Delay Start Setting	SD 0:00 SD 0:15 ... SD 4:00
GASS V	Gassing Point Setting	GPV 2.37 ... GPV 2.45
RATE	Start Rate Setting	HR 25A HR 18A
REFRSH	Refresh Charge Disabled/Enabled	YES NO
TEMP	Temperature Sense/Compensation Disabled/Enabled	YES NO

## 6.2 DEFAULT SETTINGS

Table 6.2.1

80 OFF	Charger turns off at gassing point - Enabled
FULLCH	Full Charge Period From 1:00 to 5:00 each day
BLKOUT	Block out Timer Disabled
BLOCK	Block out Period 7:00 to 16:00 each day
EQUAL	Auto Equalize at 14:00 Saturday
DLY ST	No Delay Start
GASS V	Gassing point set at 2.37VPC
RATE	Start Rate set at 25A/100AH
REFRSH	Refresh Cycle Enabled
TEMP	Temperature Sensing/Compensation Disabled (Optional Sensor Required)

## SECTION 7 REVIEW MODE (PRIOR TO CHARGE ONLY)

All programmed setup items and charge data can be reviewed in the Review Mode. Setup Data can only be reviewed prior to charge with battery disconnected. Charge Data can be reviewed any time. While "CHARGER READY" is scrolling, press DATA▲ or DATA▼ to toggle between SETUP (setup information) and CHDATA (charge data). Press ENTER to make a selection.

### 7.1 REVIEW SETUP DATA

Press DATA▲ to select the main menu, press ENTER to review setup, and press DATA▼ to exit the review menu.

Table 7.1

Review Main Menu Press DATA▲ to select	Review Menu Description	Review Sub Menu Press ENTER to view
CLOCK	Clock Setting	DD HH:MM - MM:DD:YY
80 Y 80 N	Charger Turns Off at Gassing Disabled/Enabled	
FULLCH	Full Charge Period	T ON - DD:HH:MM ...
BLKT N BLKT Y	Block out Timer Disabled/Enabled	
BLOCK	Block out Timer Setting	T OFF - DD:HH:MM ...
NO EQU 5 CYL TIMEEQ DD HH:MM	Auto Equalize	
SD 0:00 SD 0:15 ... SD 4:00	Delay Start Setting	
GPV 2.37 ... GPV 2.45	Gassing Point Setting	
HR 25A HR 18A	Start Rate Setting	
REFH Y REFH N	Refresh Charge Disabled/Enabled	
TEMP Y TEMP N	Temp. Sense/Compensation Disabled/Enabled	

## 7.2 REVIEW CHARGE DATA

Press DATA▲ to select the charge cycle, press ENTER to review the setup, and press DATA▼ to exit the review menu.

Table 7.2

Review Main Menu Press DATA▲ to select	Review Menu Description	Review Sub Menu Press ENTER to view
LAST	Charge Data of the Last Cycle Start Month:Date Start Hour:Minute Amp-Hour Returned Finish Month:Date Finish Hour:Minute Finish Voltage	MMM:DD ST HH:MM AH0000 MM:DD FT HH:MM FV V.VV
CYL 1	Cycle #1 Start Month:Date Start Hour:Minute Amp-Hour Returned Finish Month:Date Finish Hour:Minute Finish Voltage	MM:DD ST HH:MM XXXXAH MM:DD FT HH:MM FV V.VV
CYL 2	Cycle #2 Start Month:Date Start Hour:Minute Amp-Hour Returned Finish Month:Date Finish Hour:Minute Finish Voltage	MM:DD ST HH:MM XXXXAH MM:DD FT HH:MM FV V.VV
...		
CYL 24	Cycle #24 Start Month:Date Start Hour:Minute Amp-Hour Returned Finish Month:Date Finish Hour:Minute Finish Voltage	MM:DD ST HH:MM XXXXAH MM:DD FT HH:MM FV V.VV

## SECTION 8 CHARGING MODE

### 8.1 DISPLAY AND CONTROL

The front panel provides the following displays and controls to the user during charge:

Six digit Alphanumeric Display: The default display is Charge Time Remaining, the time remaining until 80% charge and until full charge will be displayed. It also displays the fault codes and charge data of the last 25 charge cycles.

“Gas Gauge” Indicator: The gas gauge contains 5 LED indicator bar and two extra LED indicators for “E” and “F”. The five level indicator displays the battery capacity returned. The “E” indicator illuminates until the battery capacity reaches 20% recharged; the “F” indicator illuminates when the battery is fully charged.

Charger Indicator:

- Charging LED (Red)
- 80% Charged (Amber)
- Charge Complete (Blue)

DATA▲ Push Button Switch

The default display is Charge Time remaining. Press DATA▲ to toggle between Charging Voltage/Current and Charge Time Remaining Display

DATA▼ Push Button Switch

Press DATA▼ to enter the Charge Data Review Mode (Refer to Table 7.3)

ENTER Push Button Switch

Press ENTER to lock in the display mode (Charging Voltage/Current or Charge Time Remaining Display)

EQUALIZE Push Button Switch

Press EQUALIZE to set the Equalize Cycle manually

STOP Push Button Switch

Press STOP to shut down the charger manually

REVIEW CHARGE DATA DURING CHARGE

Press DATA▼ then ENTER to review the current cycle data, press DATA▲ to select the next charge cycle, then press ENTER to review the charge data of the selected cycle. Pressing DATA▼ again will exit the review menu and return to the charging display.

Table 7.3

Review Main Menu Press DATA▲ to select	Review Menu Description	Review Sub Menu Press ENTER to view
DATA	Charge Data of the Last Cycle Start Month:Date Start Hour:Minute Amp-Hour Returned	MM:DD ST HH:MM 0000AH
CYL 1	Cycle #1 Start Month:Date Start Hour:Minute Amp-Hour Returned Finish Month:Date Finish Hour:Minute Finish Voltage	MM:DD ST HH:MM XXXXAH MM:DD FT HH:MM FV V.VV
CYL 2	Cycle #2 Start Month:Date Start Hour:Minute Amp-Hour Returned Finish Month:Date Finish Hour:Minute Finish Voltage	MM:DD ST HH:MM XXXXAH MM:DD FT HH:MM FV V.VV
...		
CYL 24	Cycle #24 Start Month:Date Start Hour:Minute Amp-Hour Returned Finish Month:Date Finish Hour:Minute Finish Voltage	MM:DD ST HH:MM XXXXAH MM:DD FT HH:MM FV V.VV

## 8.2 CHARGING THE BATTERY

When a proper battery is connected, the display will count down from 5 to 0, then the red CHARGING LED will illuminate. The cycle starts with high rate, constant current of 25A/100AH or 18A/100AH, until the gassing voltage is reached. The “E” LED will illuminate at the beginning of charge cycle. The Gas Gauge LEDs will indicate the state of charge.

The *80% point* can be programmed at 2.37, 2.40, 2.42 or 2.45V/Cell in the Setup mode. When the battery voltage reaches the *80% point*, the charger enters the constant voltage mode and the current gradually tapers off. When the programmed *gassing point* is reached:

- If the Gassing Shut-off function is enabled and during the full charge disabled period, the charger shuts off and goes to idle mode in order to prevent the battery from gassing. The charger will display “STOP AT 80” and the 80% CHARGED LED will illuminate. When the full charge enabled period begins, the charger will automatically turn on to complete the full charge cycle. The cool-down time will be displayed and the CHARGE COMPLETE LED will illuminate when the cycle is complete.
- If the Gassing Shut-off function is set or during the full charge enabled period, the charger will continue the regular full charge cycle.

In the regular full charge cycle, once the current drops to the finish rate current setting (5A per 100AH), the charge phase will change from constant voltage to constant current. The charge cycle will terminate by DV/DT sensing. The cool-down time “COOL HH:MM” will display, the F and CHARGE COMPLETE LEDs will illuminate at the completion of the full charge cycle.

## 8.3 EQUALIZE

Equalize cycle provides a timed three hour charge extension at the finish rate current after DV/DT termination has been reached.

Auto Equalize: The Auto Equalize is selected by Setup Mode – every charge 5 cycles or at a specific time of day and day of week (once a week). The first digit of the front panel display will display “E” and the EQUALIZE LED will flash to indicate that the Equalize charge is selected. When the charger is actually in the Equalize mode, the “E” will be flashing.

Manual Equalize: The EQUALIZE button, when pushed, will request the Equalize cycle. The first character of the front panel display will display “E” and the EQUALIZE LED will flash to indicate that the Equalize charge is selected. When the charger is actually in the Equalize mode, the “E” will be flashing. Depressing the EQUALIZE button, prior to the Equalize cycle, will cancel the Equalize function.

## 8.4 AUTO EQUALIZE DETAIL

The timed equalize charge, if selected, will occur once a week. The following paragraph outlines this feature in detail.

### AUTO EQUALIZE SELECT

Auto Equalize can be disabled, activated every 5 charge cycles or once a week at a specific time of day and day of week. Refer to Section 6.1 for the Auto Equalize setup

### AUTO EQUALIZE CANCELLATION

- Automatic equalize request cannot be cancelled by pressing the Equalize button. To cancel auto equalize select, press the STOP button to interrupt charge, disconnect then reconnect the battery.
- Manual equalize select can be cancelled by pressing the Equalize button again.

## AUTO EQUALIZE ACTIVATION

When the set time and set day are matched, equalize cycle can be activated at the following conditions:

- When the charge is in progress, the equalize cycle will start immediately after completing the 100% charge cycle.
- When the 100% charge cycle is already completed, the charger will automatically turn on to equalize charge the battery for 3 hours.
- When the 100% charge cycle is not complete, because the battery voltage reached 80% before the full charge enable window was reached (1:00 to 5:00 is default setting of the full charge enable window), the charger will immediately resume to complete the 100% charge, then add three hours of equalize charge.
- When the battery is not connected, the Equalize Cycle will be accomplished the next time the battery is connected. The charger will remain on throughout the cycle until the Equalize cycle is complete and will not shut off at the gassing point.

## FULL CHARGE TIME WINDOW

- When the battery voltage reaches the 80% point within this window, the charge cycle will continue to fully charge the battery.
- When the battery voltage reaches the 80% point outside this window, the charger will shut off and resume when the ON time is reached.
- When the OFF time is reached, the charge will continue until the charge cycle is complete.
- When the Equalize Time is set before the ON time of the full charge cycle, the charge cycle will resume, the charger will fully charge the battery then continue the 3 hour Equalize cycle.

## AUTO EQUALIZE AND FULL CHARGE ENABLE EXAMPLES

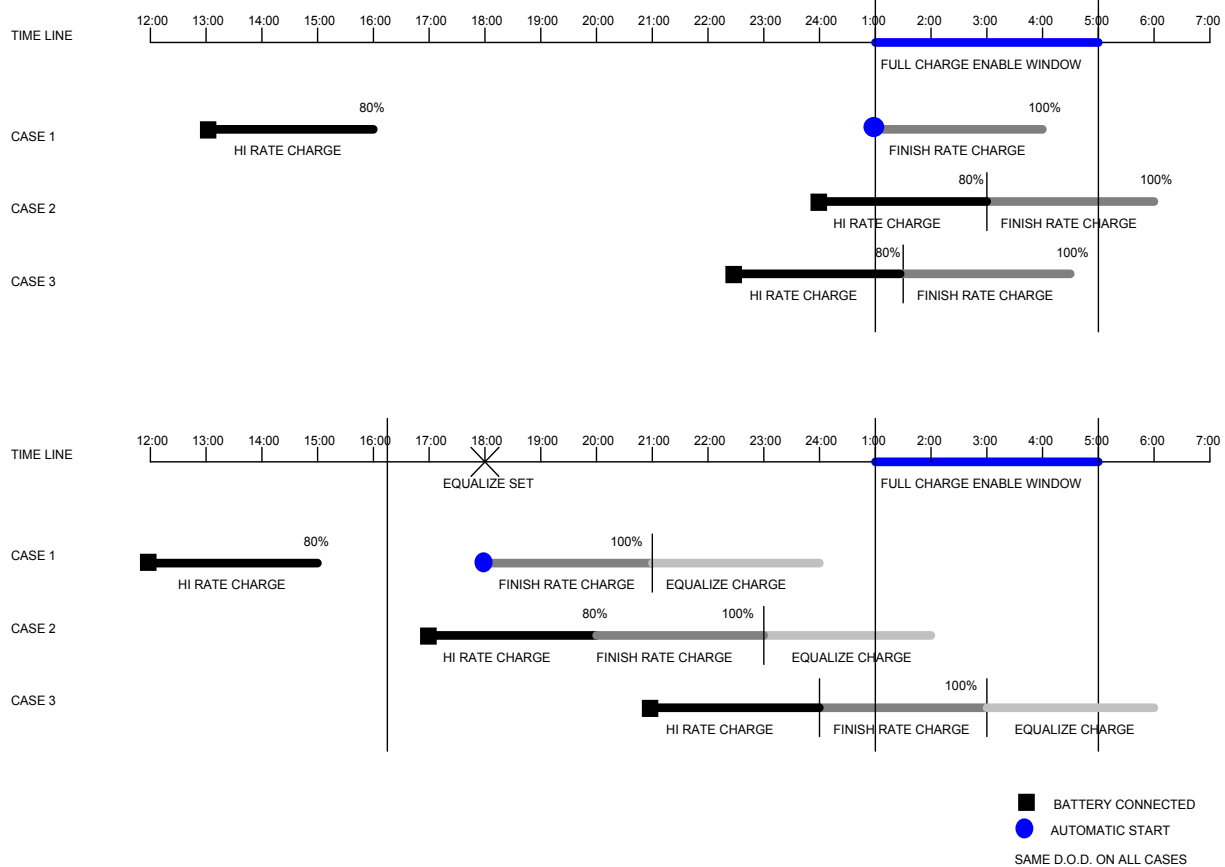

## 8.4 MANUAL TERMINATION

To manually terminate the charge cycle, press the STOP push-button switch located on the front panel. When the charge has been terminated due to manual termination, the red Fault LED will be ON solid until the battery is removed. The display will show "STOP".

## 8.5 REFRESH CHARGE

When a battery remains connected to the charger for 24 hours after the charge has been completed and the Refresh Function is enabled, the control will restart another charge cycle. The charge rate of the battery will be monitored with DV/DT termination occurring typically within 45 minutes. When the charger is in this refresh mode the CHARGING and 80% CHARGED LED's will be ON and the CHARGE COMPLETE LED will be blinking.

## 8.6 TEMPERATURE SENSING (OPTIONAL)

Refer to the user manual of the Temperature Sensor Kit for details

## SECTION 9 FAILURE MODE

### 9.1 PROBLEM SHUTDOWN

The problem shutdown terminations are indicated in Table 9.1.1. The Fault LED display will remain until the battery is disconnected from the charger. If the battery is disconnected during charge, the display will remain until the battery is connected again.

Table 9.1.1

Fault Codes	Conditions	LEDs
STOP	STOP button is pressed	Fault LED On
DISC	Battery is unplugged during charge causing internal overload	Fault & Equalize LED Flashing
DISC	Battery is unplugged during charge	Fault LED On
ERR 1	Reversed Phase or Internal Fault	Fault LED On
ERR 2	Cable between Inductor Board and Control Board is disconnected or defective	Fault LED On
ERR 3	Reversed Phase or Internal Fault	Fault LED Flashing
HIVOLT	Hi Volts (>2.8V/2.85V)	Fault LED On
LOVOLT	Low Volts (<1.7VPC)	Fault LED On
HICURR	Output Current is High (>110%)	Fault LED On
LOCURR	Output Current is Low (<7 Amps)	Fault LED On
DUR HR	Hi Rate Duration (>6 Hours)	Fault LED On
DUR LR	Lo Rate Duration (>6 Hours)	Fault LED On

## 9.2 BATTERY LOW VOLTS OVERRIDE

If the battery voltage measures less than 1.7 VPC, the charger may be started manually, by pressing and holding two push buttons (ENTER and EQUALIZE) for more than 10 seconds. If the battery does not increase above 1.7 V/Cell in 5 minutes the charger will shut off and indicate Low Volts Alarm again, otherwise the normal charge cycle will continue. This "grace period" is intended to give the battery time to recover from its over-discharged condition.

## SECTION 10 CHARGER CABINET

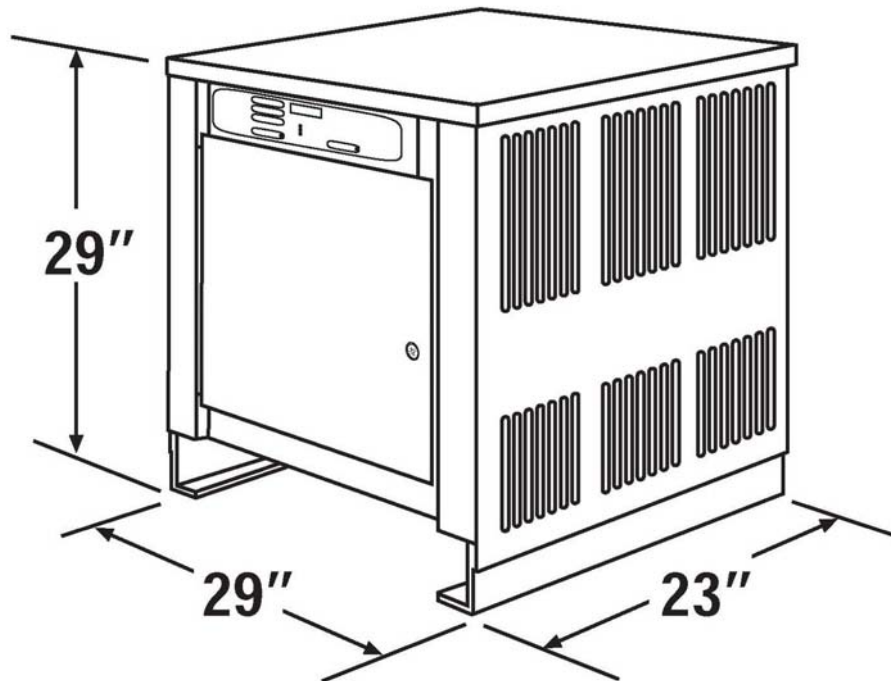

## SECTION 11 MONTHLY PREVENTIVE MAINTENANCE

### 11.1 MONTHLY PREVENTIVE MAINTENANCE

#### **WARNING**

HIGH VOLTAGES EXIST WITHIN THE CHARGER WHICH CAN CAUSE SEVERE INJURY OR DEATH. SERVICE SHOULD ONLY BE PERFORMED BY QUALIFIED SERVICE PERSONNEL. IMPROPER SERVICING MAY DAMAGE THE CHARGER.

- If a battery is being charged, terminate the charge by pressing the STOP button.
- Disconnect the battery from the charger.
- Remove AC power from the charger.
- Using compressed air, remove any dust from the inner cabinet walls and internal components of the charger.

- Wipe the exterior of the cabinet and clear any obstructions from the ventilation louvers.
- Make sure that all bolted or screwed electrical connections are tight.
- Make sure that the insulation on all cables and wires are in good condition. Replace if necessary.

## 11.2 CHARGER ADJUSTMENTS

### 11.2.1 Changing the AC Input Line Voltage

The QuarterHorse chargers are designed to operate at different voltage levels. The chargers can be ordered for 240/480/575 volts or 480/575/600 volts 60 Hz electric services.

If the charger is to be operated on a different rated input voltage than the ordered value, follow the voltage changeover instructions described below (Refer to Figures 11.1.1 or 11.1.2).

### 11.2.2 Voltage Changeover Instructions

- Manually terminate the charging battery by pressing the STOP button and disconnect battery from charger.
- Remove AC power from the charger.
- Locate the Terminal Block with Jumpers and the label describing the various voltage/jumper configurations. (Refer to Figures 11.1.1 or 11.1.2). The Terminal Block with Jumpers is located on the Ferro-resonant Transformer.
- Change the jumpers in accordance with the Jumper label, located within the charger cabinet, for the voltage input configuration desired.
- Locate the AC fuses and fuse label. Change the fuses to the appropriate value as indicated by the circled values on the fuse label.
- Locate the Control transformer. Change the primary input connection in accordance with the voltage printed on the transformer. (Refer to Figure 11.2)
- Change the voltage level on the STOP label to the new voltage level.
- Check list:
  - Verify that the Terminal Block(s) with Jumpers are configured correctly and screw connections are tight. Make sure that all of the Terminal Blocks with Jumpers have been changed properly.
  - Verify the installation of properly rated fuses.
  - Verify that the Control Transformer primary taps have been changed correctly.
  - Verify that the STOP label, located inside the door, has been corrected to the new input voltage level that the charger is set for.
- Close and secure the cabinet.
- Connect the AC power to the charger.

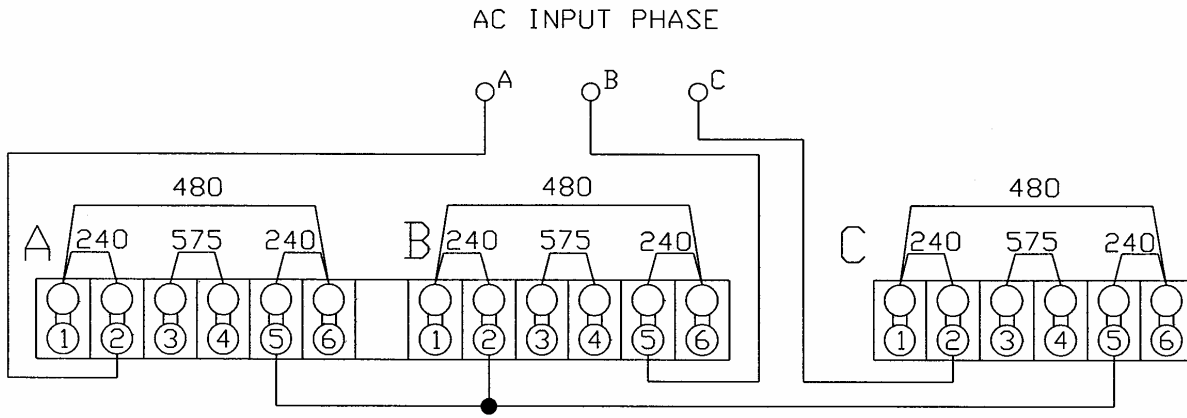

FIGURE 11.1.1 A.C. VOLTAGE SELECTOR BLOCKS (240/480/575V)

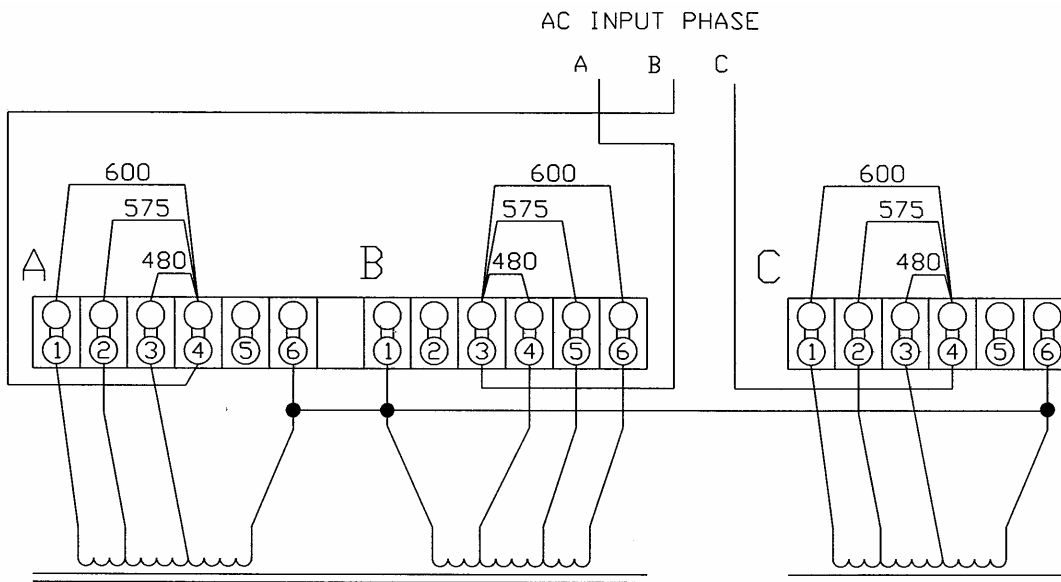

FIGURE 11.1.2 A.C. VOLTAGE SELECTOR BLOCKS (480/575/600V)

NOTE: INPUT VOLTAGE SETTING FOR CONTROL TRANSFORMER  
(LEADS FROM AC INPUT MUST BE EXACT) TO AC LINE CONTACTOR

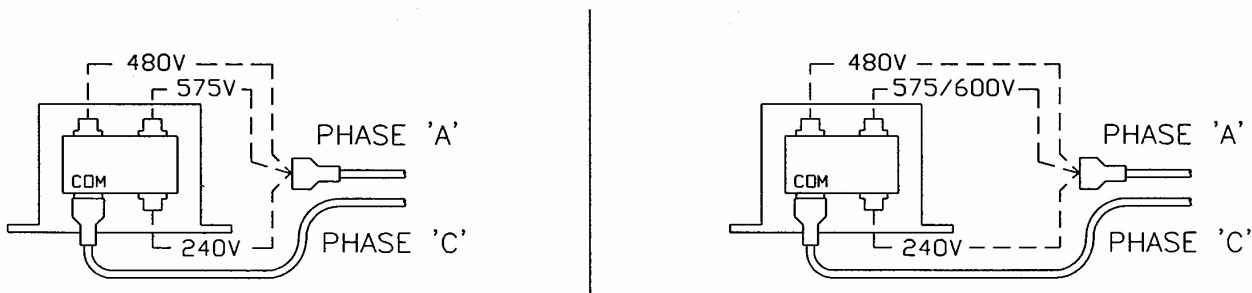

FIGURE 11.2  
A.C. VOLTAGE SELECTION ON PRIMARY SIDE OF CONTROL TRANSFORMER

**WARNING**

HIGH VOLTAGES EXIST WITHIN THE CHARGER WHICH CAN CAUSE SEVERE INJURY OR DEATH. SERVICE SHOULD ONLY BE PERFORMED BY QUALIFIED SERVICE PERSONNEL. IMPROPER SERVICING MAY DAMAGE THE CHARGER.

**SECTION 12      TROUBLESHOOTING GUIDE*****SYMPTOM 1      POWER IS APPLIED BUT THE DISPLAY IS NOT ON***

- Make sure the input line from the AC power outlet is connected at the AC fuse block properly. Verify the AC voltage at the fuse block.
- Locate the control transformer. Verify the voltage at the primary of the transformer. If there is no voltage, check the wiring between the control transformer and the contactor.
- Verify the secondary voltage of the control transformer across terminals 5 and 7. The voltage should be approximately 18-20 Volts RMS. If there is no voltage, the transformer is defective and should be replaced. If the secondary voltage is extremely high or low, verify that the AC voltage is connected to the proper primary inputs of the control transformer. (Refer to SECTION 11.2.2)
- Locate the Main Control Board and the Cell Select Board. Verify the proper connection of the boards and cables.

***SYMPTOM 2      DISPLAY IS ON BUT CHARGER WILL NOT START***

- If the “**CHARGER READY**” is displayed, check the battery connections and the output fuse for open fuse.
- If “**HIVOLT**” is displayed, verify that the number of cells of the battery to be charged matches the number of cells on the nameplate (located on the external surface of the door).
- If “**LOVOLT**” is displayed, verify that the number of cells of the battery to be charged matches the number of cells on the nameplate. If the number of cells matches, the battery might have been over-discharged. Refer to Section 9.2 for Low Volts Override operation.

***SYMPTOM 3      DISPLAY COUNTS DOWN BUT SHUTDOWN IMMEDIATELY***

- If “**ERR 2**” is displayed, check the 20-pin flat cable between main control board on the back of the front panel and inductor board mounted on the chassis.
- If “**ERR 1**”, “**ERR 3**” or “**HICURR**” is displayed within first 10 seconds after power-up, try reversing two of the AC input leads to see if this solves the problem.
- If “**ERR 1**”, “**ERR 3**” or “**HICURR**” is displayed after 10 seconds, the following checklist should be performed to resolve this problem:
  - Is cable harness connected properly between the main control board and the inductor board?
  - Is “**COMMON**” of the control transformer connected to the AC input phase ‘C’ (see schematic)?
  - Is the other terminal of the control transformer connected to the AC input phase ‘A’ (see schematic)?
  - Check all diodes and capacitors

For 240/480/575V AC input models

- Is phase “A” wiring, as indicated on the label at the AC Fuse Block, connected to terminal “A” of the main transformer T1 through the contactor? (main transformer T1 has the 12-position terminal block) (See schematic)?
- Is phase “B” wiring, as indicated on the label at the AC Fuse Block, connected to terminal “B” of the main transformer T1 through the contactor? (main transformer T1 has the 12-position terminal block) (See schematic)?
- Is phase “C” wiring, as indicated on the label at the AC Fuse Block, connected to terminal “C” of the tickler transformer T2 through the contactor? (tickler transformer T2 has the 6-position terminal block) (See schematic)?

For 480/575/600V AC input models

- Is phase “A” wiring, as indicated on the label at the AC Fuse Block, connected to terminal “B” of the main transformer T1 through the contactor? (main transformer T1 has the 12-position terminal block) (See schematic)?
- Is phase “B” wiring, as indicated on the label at the AC Fuse Block, connected to terminal “A” of the main transformer T1 through the contactor? (main transformer T1 has the 12-position terminal block) (See schematic)?
- Is phase “C” wiring, as indicated on the label at the AC Fuse Block, connected to terminal “C” of the tickler transformer T2 through the contactor? (tickler transformer T2 has the 6-position terminal block) (See schematic)?
- Are the cables from capacitor winding 7 of the main transformer T1 and from terminal M3 of the inductor board connected to the same side of the resonant capacitor?
- Is the cable from capacitor winding 8 of the main transformer T1 connected to the power resistor mounted near the capacitor?
- Are the cables from the other side of the power resistor and from terminal M4 of the control assembly connected to the same side of the capacitor?
- Are the cables from capacitor winding 7 of the second transformer T2 and from terminal M1 of the inductor board connected to the same side of the resonant capacitor?
- Is the cable from capacitor winding 8 of the second transformer T2 connected to the power resistor mounted near the capacitor?
- Are the cables from the other side of the power resistor and from terminal M2 of the control assembly connected to the same side of the capacitor?

**SYMPTOM 4            CHARGE TERMINATES EARLY**

- Fault code “**LOVOLT**” - Low volts per cell - the average battery voltage is less than 1.5 V/Cell. Check for bad cells.
- Fault code “**HIVOLT**” - High volts per cell - the average battery voltage is greater than the high voltage limit. The battery may be fully charged before connecting to the charger.
- Fault code “**DISC**” - Battery is disconnected from charger during charge.
- Fault code “**DUR HR**” or “**DUR FR**” - Charge time exceeded – the battery voltage did not reach the gassing point within the specified time in High Rate or does not shut off within 6 hours from Gassing Point. Check for bad cells or deep discharge condition.
- Fault code “**LOCURR**” - Low charging current – no charging current detected or charging current is too low. Check the DC fuse for open fuse and defective AC contactor circuit.
- Display “**STOP**” - Charge cycle is terminated by pressing the STOP button.

**SECTION 13 SCHEMATICS**

*See following page*

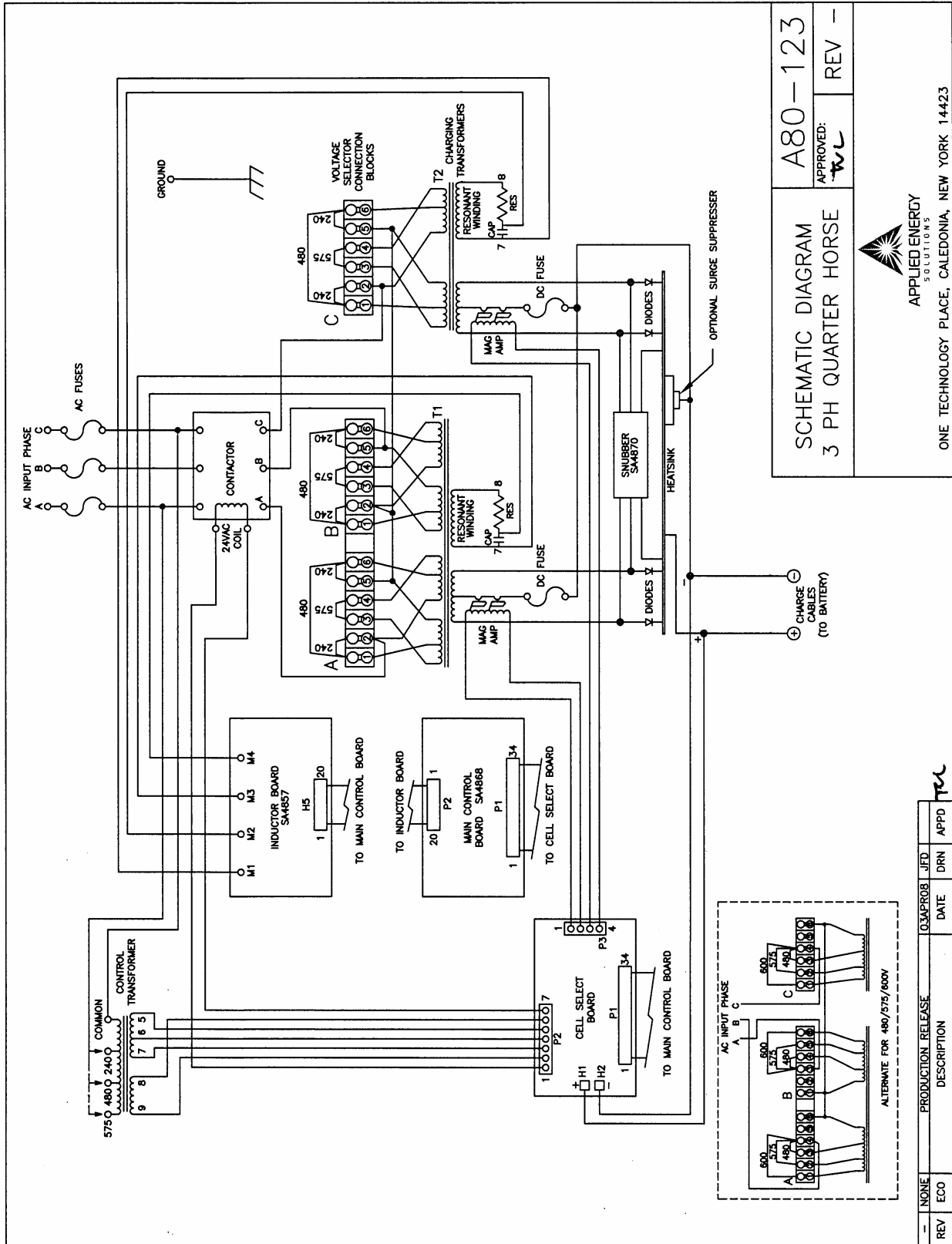

**SCHEMATIC DIAGRAM**  
3 PH QUARTER HORSE

APPROVED: *TL*

A80-123

REV -



APPLIED ENERGY SOLUTIONS  
ONE TECHNOLOGY PLACE, CALEDONIA, NEW YORK 14423

REV	ECO	NONE	DESCRIPTION	DATE	DRN	JFD	APPD
-			PRODUCTION RELEASE				

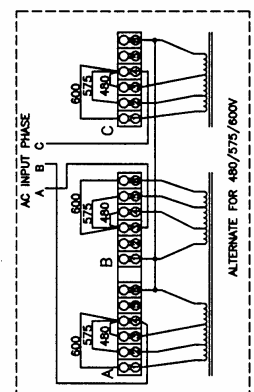

## **CHARGER WARRANTY**

APPLIED ENERGY SOLUTIONS warrants that each new and unused battery charger manufactured and supplied with good workmanship is free from any known mechanical defect, provided that (A) the product is installed and operated in accordance with the accepted industrial standards and in accordance with the printed instructions furnished by APPLIED ENERGY SOLUTIONS, (B) the product is used under normal conditions for which designed, (C) the product is not used in a corrosive, abnormally dusty or high humidity moisture condensing environment, and (D) the product is not subjected to misuse or negligence, and the product receives proper care, protection and maintenance under supervision of competent personnel.

### **Warranty Terms and Conditions**

APPLIED ENERGY SOLUTIONS QuarterHorse Industrial Battery Chargers are warranted for 10 Years<sup>(1)</sup>, which begins on the date of shipment from APPLIED ENERGY SOLUTIONS.

NOTES: <sup>(1)</sup>Warranty covers parts and labor,  
AC fuses and DC fuses are not warranted unless they are found to be defective prior to use.

NON-TRANSFERABLE WARRANTY. This warranty is extended by APPLIED ENERGY SOLUTIONS only to the original user (purchaser) of new equipment from APPLIED ENERGY SOLUTIONS or one of its authorized agents. The product purchased under this agreement shall be used exclusively by the buyer. There shall be no third party beneficiary of this warranty.

REPAIR LIMITATIONS. APPLIED ENERGY SOLUTIONS has the right to site inspection and judgment of the claimed defects in any product covered by this warranty. APPLIED ENERGY SOLUTIONS' liability is limited to the repair of any defects found to exist by APPLIED ENERGY SOLUTIONS or, at APPLIED ENERGY SOLUTIONS' option, the replacement of the defective product.

APPLIED ENERGY SOLUTIONS and its authorized agents shall not be liable for direct or indirect damages in excess of such repair or replacement. In no event shall the purchaser be entitled to recover for contingent expenses from, but not limited to, telephone calls, telegrams, travel expenses, lodging, duties and taxes, labor, rental or replacement equipment, loss of business or profit or other commercial losses.

CONTINUED USE OF DEFECTIVE PRODUCTS. The continued use of an APPLIED ENERGY SOLUTIONS Industrial Battery Charger that is known to be defective VOIDS ALL WARRANTIES.

REPAIR OF MODIFIED EQUIPMENT. Except as authorized in writing the warranty specified does not cover any equipment that has been repaired by any party other than APPLIED ENERGY SOLUTIONS or its authorized agents. Except as authorized in writing the warranty specified does not cover any equipment that has been modified, mechanically or electrically, by any party other than APPLIED ENERGY SOLUTIONS.

WARRANTY EXPENSE LIMITATIONS. APPLIED ENERGY SOLUTIONS will limit the warranty expense of all chargers to be paid at a maximum of the original purchase price of the charger.

The provisions of this warranty shall not apply to product in use outside of the continental USA.

Except as stated above, all other warranties and conditions, either expressed or implied, including implied warranties of merchantability and fitness for a particular purpose, are excluded and buyer assumes all risk and liability resulting from the use of the goods. APPLIED ENERGY SOLUTIONS neither assumes or authorizes any persons to assume for APPLIED ENERGY SOLUTIONS any other liability in connection with the sale or use of the goods sold and there are no oral agreements or warranties collateral to or affecting this written warranty. When installing, servicing or operating these products, safe practices should be used by skilled and qualified technical persons.